

DURAMAX[®]

Mechanical Face Seal System

- ▷ Commercial Grade
- ▷ Engineered for Propeller Shafts and Rudder Assemblies
- ▷ Face Seal Configuration



Available In 3 Mounting Methods:
BRZ SYSTEM (shown) - Steel Hull
FRP SYSTEM - Fiberglass Hull
WELD-ON SYSTEM - Aluminum Hull



PRODUCT INFORMATION AND SELECTION GUIDE

Duramax Marine[®] is an ISO 9001:2015 Certified Company

DURAMAX MARINE[®]



The Next Generation of Mechanical Face Seals.

Through extensive research, Duramax Marine identified numerous design inefficiencies in many of today's mechanical seal designs.

These design problems can result in increased downtime, lower productivity and even hefty water pollution fines.

Duramax Marine shaft seal experts, based on their research, designed this revolutionary solution—The Duramax Mechanical Face Seal System.



A mechanical face seal is a great choice but many come with hidden design problems.

The face seal is designed with two finely-machined surfaces or faces located perpendicular to the shaft and pressed together to form a seal. One face surface - the seal ring - is attached to and turns with the propeller shaft. The other face surface -the friction ring - is part of the seal body. It remains stationary and does not turn with the shaft. The seal ring and the friction ring are arranged so that they are always in contact with each other. The seal body is normally a compressed rubber bellows or spring-loaded bellows that forces the stationary friction ring against the rotating seal ring. This creates a very effective and leak-proof seal.

Since face seals do not use the propeller shaft as a sealing surface, you do not have shaft wear caused by the packing in stuffing boxes or the rubber lips found in lip seals. Also, the shaft is allowed to rotate with less resistance, which increases fuel economy and helps provide better propulsion system performance.

The friction ring and the seal body have an inside diameter larger than the propeller shaft diameter. This prevents the propeller shaft from hitting the seal body and causing leakage through the seal faces. This also allows for shaft misalignment, excessive dimensional runout and vibration in the propulsion system.

Today there are many face seal designs to choose from. The difference among them are the method of installation and removal, type of materials used and design features.

CARBON FACE SEALS

Design Flaws Lead to Shaft Damage, Leakage and Seal Failure.

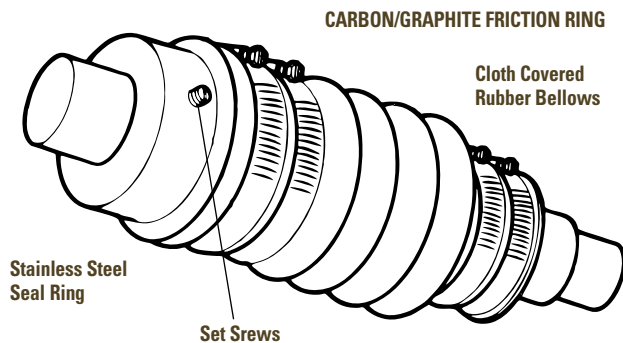

Carbon graphite is very brittle and causes corrosion of stainless steel.

The seal face consists of carbon graphite, which is brittle and subject to chipping, scratching or pitting. This can result in leakage and seal failure. Also, carbon graphite used in salt water can create galvanic corrosion of the stainless steel shafting materials. Stainless steel shafting manufacturers advise against the use of carbon graphite with stainless steel shafting.

Seal ring design makes it very difficult to install or remove.

Embedded in the inside diameter of the seal ring are two O-rings that keep water from leaking past the seal ring into the vessel. The seal ring inside diameter is only slightly larger than the diameter of the propeller shaft. This close tolerance between the shaft and seal ring requires careful installation or you could damage these O-rings by cutting them on the key-way slots. If you damage the O-rings, there will be leakage through the inside diameter of the seal ring. Also, if there is galling or marking on the shaft, the seal ring cannot be installed without first polishing the shaft.

Seal ring setscrews can damage the propeller shaft.

The seal ring is secured to the propeller shaft with setscrews which are tightened into and can damage the surface of the propeller shaft. The setscrews also electrically connect the seal ring to the propeller shaft and can lead to galling and/or electrolysis. If the seal ring galls to the shaft, it must be cut into pieces to remove it.

CONICAL FACE SEALS

Any Shaft Vibration or Misalignment Will Cause Leaks.

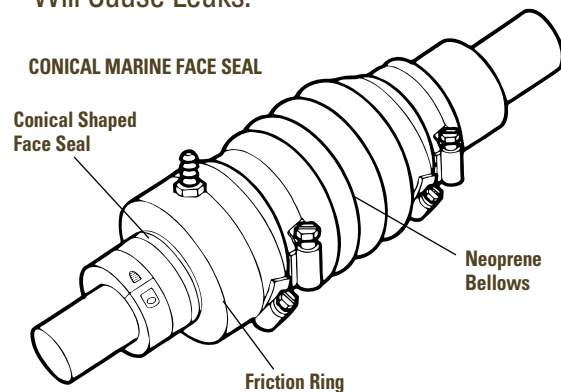

Conical marine face seals have a seal ring with a beveled face and a mating friction ring with a counter bevel. Any vibration or misalignment will cause the conical face to wear into an oval or elliptical shape. This prevents the seal from seating correctly, causing it to leak.

Only good in low RPM operations.

These seals work in low RPM applications, but for most marine applications, the propeller shaft RPM is too high and there is too much propulsion system movement for this type of face seal to operate properly.

BELLOWS TYPE FACE SEALS

Bellows-type seals offer minimum protection if breakdown occurs.

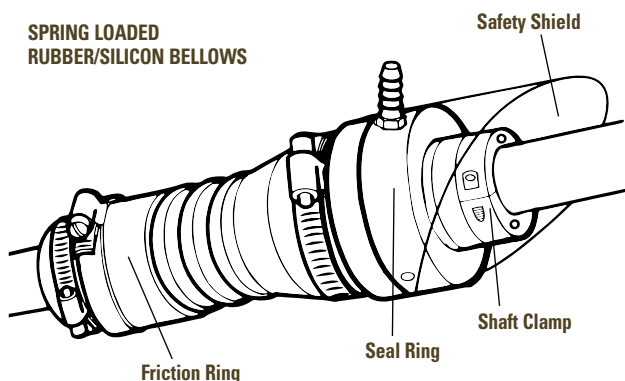

Any bellows-type seal uses the bellows as the only barrier between you and the sea. If the bellows should fail or be damaged, a serious leakage situation will occur.

A rubber bellows is adversely affected by temperature, environment and age.

Both the Carbon Face Seal (fig. 1) and the Conical Face Seal use a convoluted rubber bellows as the seal body and to maintain the required pressure on the seal faces. When a rubber bellows is used as a spring, the seal depends on the compressibility and durometer (hardness) of the rubber to maintain pressure at the faces to create the seal.

The main problem with this type of seal is that the physical properties of rubber, regardless of type, are affected by temperature, environment and age. As the aging rubber loses its physical properties, the amount of pressure on the seal face decreases. This can result in seal leakage and requires you to adjust the face pressure by adding additional compression to the rubber bellows or eventually replacing the rubber bellows.

Rubber eventually deteriorates, cracks and leaks.

As rubber ages, it becomes less compliant and brittle to the point where it will deteriorate, crack and leak. Several face seal manufacturers have recognized this problem and have incorporated fabric reinforcement in an attempt to assist with structural strength. Also, several manufacturers have molded a spring into their rubber bellows. This is an improvement over the convoluted rubber bellows because the spring maintains a constant pressure on the seal faces for the life of the seal. However, it does not eliminate the aging process of the rubber itself.

Bellows can be accidentally jarred out of position.

Another problem with bellows-type face seals is that the flexibility of the bellows can allow the seal faces to be accidentally knocked off their seat or sealing surfaces which will allow a major leakage of water into the vessel.

LIP SEALS

Tight fit of lip to propeller shaft creates seal, as well as leaks.

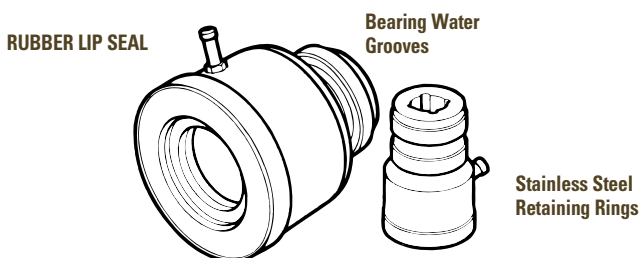

Another common type of mechanical seal used on rotating propeller shafting is the lip seal. Lip seals are similar to stuffing boxes in that they utilize the propeller shaft as a sealing surface. A rubber ring with a lip on the inside diameter fits over the propeller shaft. The tight interference fit between the rubber lip and the propeller shaft ensures continuous contact and creates a seal.

Shaft imperfections will damage lip seal, result in leakage.

In order for the lip seal to operate properly, the propeller shaft must be very smooth. If the shaft is pitted or marred, it will damage the lip seal or will not allow a proper fit of the lip seal to the shaft. This will result in leakage through the lip seal.

Frictional heat causes lip seal and propeller shaft wear.

The rubber lip seal is not a very effective solution for sealing marine propeller shafts. As the propeller shaft turns, frictional heat is created which causes the rubber lip seal and propeller shaft to wear - leading to eventual leakage through the lip seal.

Lip seal causes severe wear on stainless steel.

Shaft wear can be severe when using a lip seal with stainless steel shafting material. Stainless steel has great tensile strength but due to its high nickel content, it has low resistance to abrasion. Another problem when using a rubber lip seal with stainless steel shafting is crevice corrosion. The tight interference fit of the rubber lip to the stainless steel shaft results in oxygen deprivation of the stainless steel and the shaft cannot oxidize to protect itself. This results in a groove being etched into the shaft - causing the lip seal to leak.

Shaft misalignment, vibration will cause seal leakage.

Propeller shaft misalignment and shaft line vibration will cause lip seals to leak. One lip seal manufacturer has tried to solve this problem by incorporating into his design a propeller shaft bearing to assist with reducing the shaft line vibration that causes seal leakage.

Problems occur with both single- and double-lip seal systems.

Several types of lip seals are available for sealing marine propeller shafts. They vary in the number of rubber lips used per seal assembly and the type of lubricant used. One type uses a single lip with water lubrication. Another type uses a double lip seal lubricated with transmission fluid. This seal has a reservoir of more than 16 ounces of transmission fluid. As the seal wears, transmission fluid can leak out into the seawater which could result in federal water pollution fines.

The Revolutionary Mechanical Face Seal Solution.

Simply put, the superior design of the Duramax Shaft Seal System makes it the best choice for your shaft seal requirements.

It eliminates the inefficiencies of all other designs. The Duramax system is easy to install and remove and increases performance.

This "maintenance-free" mechanical face seal has run in some applications for over 20,000 running hours without requiring replacement parts*. And, maintenance-free means there are no lip seals or packing to change - and no need for constant adjustment once properly installed.

*This service life is not guaranteed, it may vary depending upon conditions of use.



THE DURAMAX SHAFT SEAL SYSTEM DESIGN FEATURES

NYLON FRICTION RING eliminates the problems associated with carbon graphite.

The Duramax Friction Ring is the stationary part of the seal face. It is made of impact-resistant, high temperature, oil-impregnated nylon that is impervious to shock or blows. It can withstand high temperatures up to 350° Fahrenheit. This material also eliminates the galvanic corrosion and brittleness problems associated with carbon graphite materials.

UNIQUE TWO-PIECE SEAL RING/ SHAFT CLAMP ASSEMBLY Allows for easy installation and removal.

The Duramax Seal Ring/Shaft Clamp Assembly has a unique two-piece design. A non-conductive Delrin** shaft clamp is utilized to attach the assembly to the propeller shaft. It is a true split clamp design that does not gall or mark the shaft when it is clamped in place.

ASSEMBLY ELECTRICALLY ISOLATES the seal ring from the propeller shaft.

The Duramax Shaft Clamp/Seal Ring design electrically isolates the stainless steel seal ring from the propeller shaft and eliminates the galling of the seal ring to the propeller shaft. Also completely eliminated is damage caused by attaching the seal ring to the propeller shaft with setscrews.

**Delrin is a registered trademark of E.I. DuPont De Nemours & Co. (Inc), Wilmington, Delaware

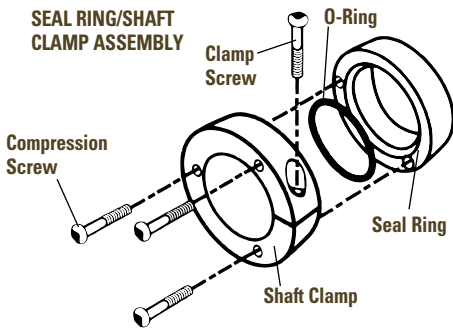

Plus, it opens large enough to slide over the propeller shaft even if it is galled or pitted! The 316 stainless steel seal ring is designed with the inside diameter machined 0.015 inches (0.38mm) larger than the propeller shaft. It has a 45-degree bevel machined in the inside diameter which allows an O-ring to be compressed into the slope when the seal ring is attached to the shaft clamp.

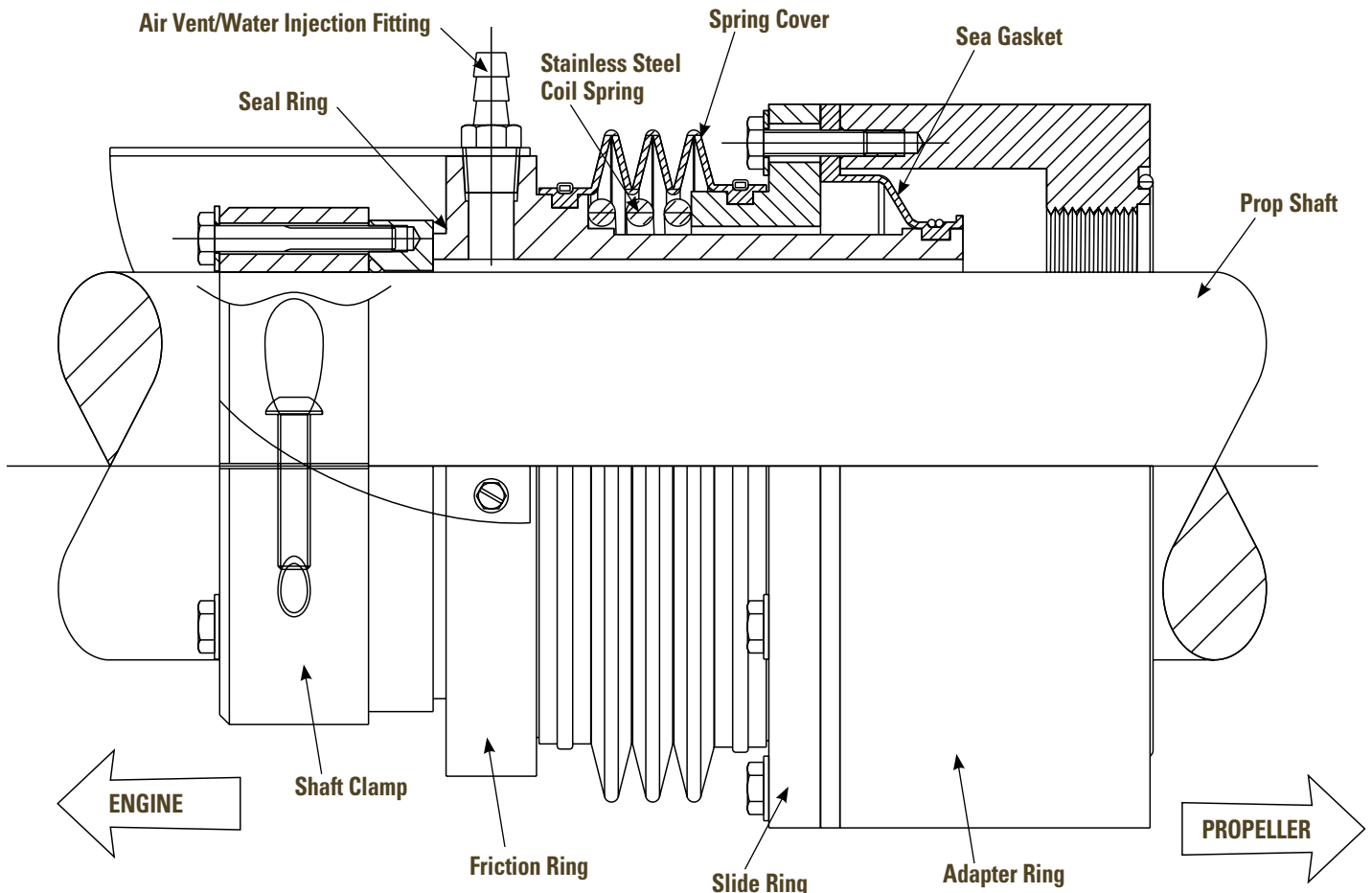

**COMPOSITE, NON-RUBBER
MAIN SEAL BODY
eliminates the weakest point
of standard seals.**

Most mechanical seals use a rubber bellows or spring-loaded rubber/silicone hose to connect the seal to your boat. This type of connection works - however, it is the weakest point of the seal assembly. If the bellows or hose is punctured or if the material weakens or fails, large amounts of water will enter the vessel. Also, severe leakage will occur if someone steps on the seal body or accidentally displaces the seal off center.

The Duramax Main Seal Body has been designed to eliminate the use of a rubber bellows or spring-loaded hose. It employs a rigid, spring-loaded, composite body that cannot be knocked off the seal face. The main seal body is attached to an adapter ring by a neoprene sea gasket. If this sea gasket were to fail, the seawater would enter the sealed spring chamber. This special design feature provides a secondary seal to the main body seal and would prevent the entry of seawater into the vessel.

**STAINLESS STEEL TENSION
SPRING ensures a reliable seal.**

In order for a mechanical face seal to work properly, face tension or pressure must be placed on the rotating seal ring and the stationary friction ring. This tension

creates the seal between the two faces. Mechanical face seal manufacturers who utilize a rubber bellows rely on the compressibility and durometer of the rubber to maintain the face tension. As the rubber ages and loses its physical properties, the amount of face pressure decreases, which affects the reliability of the seal. The Duramax Shaft Seal System eliminates the problems associated with rubber bellows by utilizing an engineered 316 stainless steel coil spring. The spring diameter and number of coils have been designed and tested to provide the proper face pressure that creates a reliable seal and ensures a long wear life of the seal faces.

**AIR VENT/WATER INJECTION
FITTING ensures adequate water
lubrication.**

In order for a mechanical face seal to work correctly, a thin film of water is required between the two seal faces. This water film acts as a lubricant, carries away frictional heat and maintains the proper seal face temperature. Every Duramax Shaft Seal System has an air vent/water injection fitting that provides adequate water lubrication at the seal face. For a displacement hull (sailboat, trawler, etc.) - the fitting is used to vent or bleed off any air trapped at the seal face, which could prevent water from reaching the seal faces.

For high-speed hulls (approximately above 12 knots) - as the vessel reaches higher speeds, a vacuum can occur on the stern tube which draws the lubricating seawater outboard and starves the seal faces. In these types of installations, the fitting is used to inject water to the seal faces.

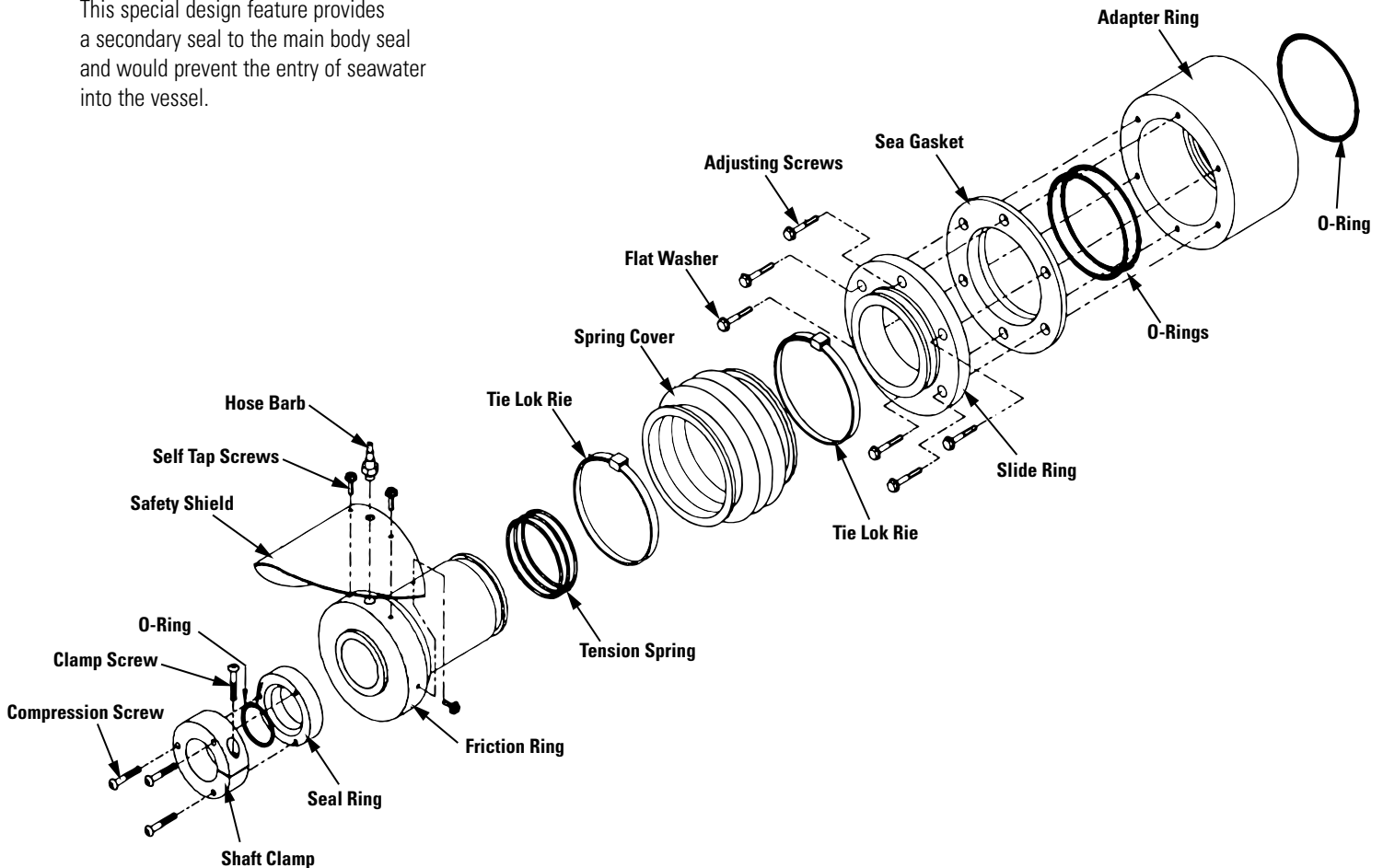

Choosing the Right Duramax® Shaft Seal System for Your Vessel is Easy.

The Duramax Shaft Seal System, manufactured in the U.S.A., is available for shafts from 3/4 to 6-3/4 inches diameter. They are easy to install for the O.E.M. or retrofit installations.

To find the right one, go to the "DXU Shaft Seal Assembly" data sheet and look in the left-hand column for your shaft diameter. Right next to the shaft diameter listing is the part number for the Duramax Shaft Seal Assembly.

We offer three different shaft seal system designs to meet your specific need.

Our sales engineers are ready to answer your questions and provide assistance with selecting the Duramax Shaft Seal System. Please call us at 440-834-5400 or FAX us at 440-834-4950, or visit our website, www.DuramaxMarine.com.

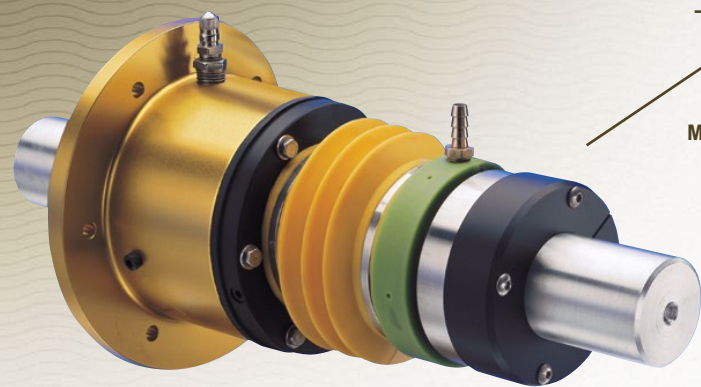

THE DURAMAX BRZ SHAFT SEAL SYSTEM

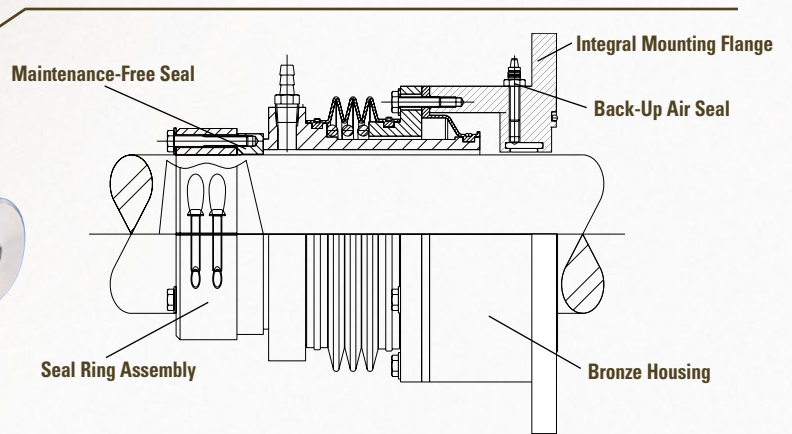

The Economical Choice for Pleasure or Commercial Vessels.

Whether your vessel is a mega yacht or a passenger ferry, this system is ideal. It incorporates the Duramax Shaft Seal System with either an aluminum or bronze adapter ring housing with an integral mounting flange and back-up air seal feature. Now, you can inflate the back-up air seal while the shaft is stationary - allowing you to make minor adjustments to the seal and stop water flow in the case of catastrophic failure of the seal. And, the integral mounting flange is undrilled to make attachment simple - you can use your own bolt pattern. For shaft diameters 2-1/2 - 6-3/4 inches.

THE DURAMAX FRP SHAFT SEAL SYSTEM

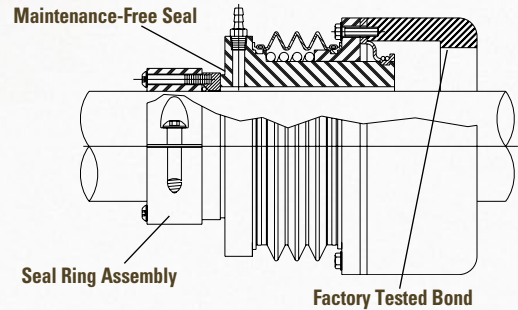

Designed with the Fiberglass Builder in Mind.

Perfect for new fiberglass vessel construction, this system incorporates the "maintenance-free" Shaft Seal System with an integrated FRP stern tube and a Johnson Cutless, Bearing. The factory-tested bond between shaft seal and FRP tube verifies seal attachment to stern tube. And, the FRP stern tube saves production time by allowing you to fiberglass the engineered system directly into your boat.

THE DURAMAX WELD-ON SHAFT SEAL SYSTEM

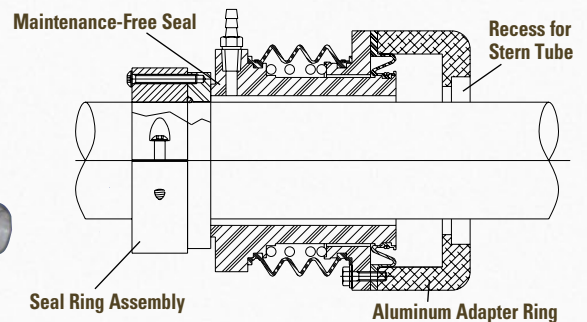

Designed with the Aluminum Builder in Mind.

When constructing an aluminum vessel, this is ideal for you. It incorporates the "maintenance-free" Duramax Shaft Seal System with an aluminum adapter ring. This ring saves production time by allowing the installer to weld the seal assembly directly to the aluminum stem tube - thus eliminating the need for a seal adapter, hose and hose clamps. And, the compression clips pre-compress the tension spring for easier installation.

For production boat builders, Duramax has additional design options not shown in this booklet. Contact us for more information on these options.

WE ADAPT OUR SYSTEM TO YOUR VESSEL - RATHER THAN YOU ADAPTING YOUR VESSEL TO OUR SEAL.

In order to reduce installation time and save you money, Duramax has designed and developed a series of mounting adapters for flanged, hose connection, stern tube and through-hull installations. These adapters allow us to adapt the Duramax Shaft Seal System to your vessel.

To select the proper adapter for your stern tube or deadwood attachment, go to the adapter data sheets on the following pages. You will need to know the outside diameter size of your stern tube and the space available from the aft end of your shaft coupling to the forward end of the stern tube.



DXU Shaft Seal Assembly

The shaft seal assembly is the main body of the Duramax Shaft Seal System. To determine which assembly to order, measure the propeller shaft diameter and match the shaft size on the adjacent chart.

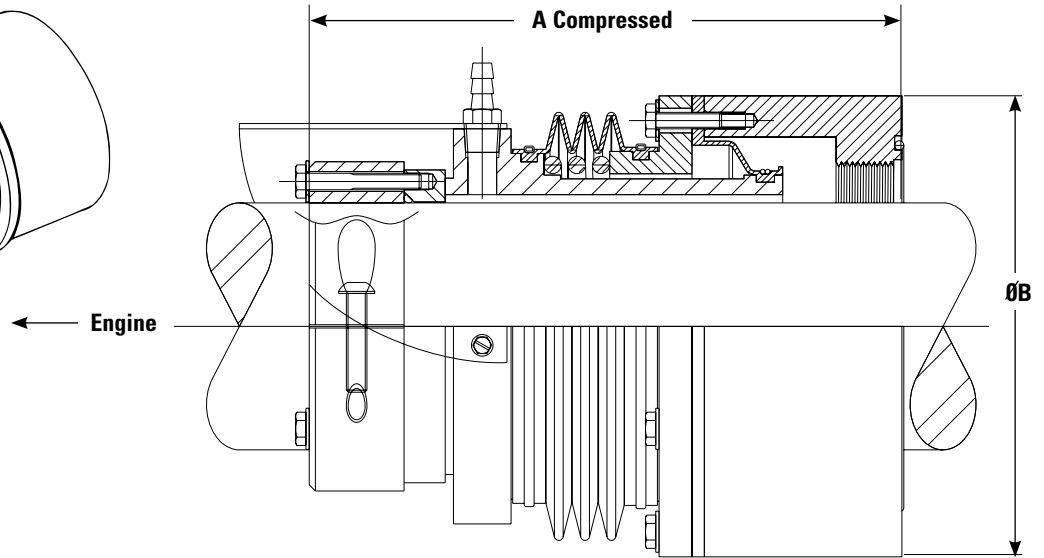
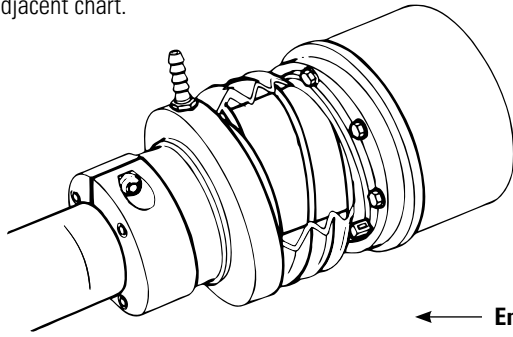

Shaft Size	A	B
3/4	7-1/2	3-1/2
7/8	7-1/2	3-1/2
1	7-5/8	4-1/2
1-1/8	7-5/8	4-1/2
1-1/4	7-5/8	4-1/2
1-3/8	7-5/8	4-1/2
1-1/2	7-5/8	4-1/2
1-3/4	7-13/16	4-1/2
2	7-7/8	5-1/2
2-1/4	7-7/8	5-1/2
2-1/2	8-3/8	5-1/2
2-3/4	8-3/8	5-1/2
3	9-1/4	7
3-1/4	9-1/8	7
3-1/2	9-1/8	7
3-3/4	9-1/8	7
4	9-1/2	8
4-1/4	9-1/2	8
4-1/2	9-1/2	8
4-3/4	10-1/4	8
5	10-15/16	10
5-1/4	10-15/16	10
5-1/2	10-15/16	10
5-3/4	10-15/16	10
6	10-15/16	11
6-1/4	10-15/16	10
6-1/2	10-15/16	11
6-3/4	10-15/16	11

Shaft Diameter	Adapter Part Number
3/4"	DXU-0750
7/8"	DXU-0875
1"	DXU-1000
1-1/8"	DXU-1125
1-1/4"	DXU-1250
1-3/8"	DXU-1375
1-1/2"	DXU-1500
1-3/4"	DXU-1750
2"	DXU-2000
2-1/4"	DXU-2250
2-1/2"	DXU-2500
2-3/4"	DXU-2750
3"	DXU-3000A
3-1/4"	DXU-3250
3-1/2"	DXU-3500
3-3/4"	DXU-3750
4"	DXU-4000A
4-1/4"	DXU-4250A
4-1/2"	DXU-4500A
4-3/4"	DXU-4750A
5"	DXU-5000
5-1/4"	DXU-5250
5-1/2"	DXU-5500
5-3/4"	DXU-5750
6"	DXU-6000

If your size is not listed, please call Duramax Marine at 440-834-5400

IXU Deluxe Installation Kit

The deluxe installation kit includes water connection fittings with hose and clear vinyl safety shield. If your shaft size is not listed, please call Duramax Marine.

*If your shaft size is not listed,
please call Duramax Marine at 440-834-5400*

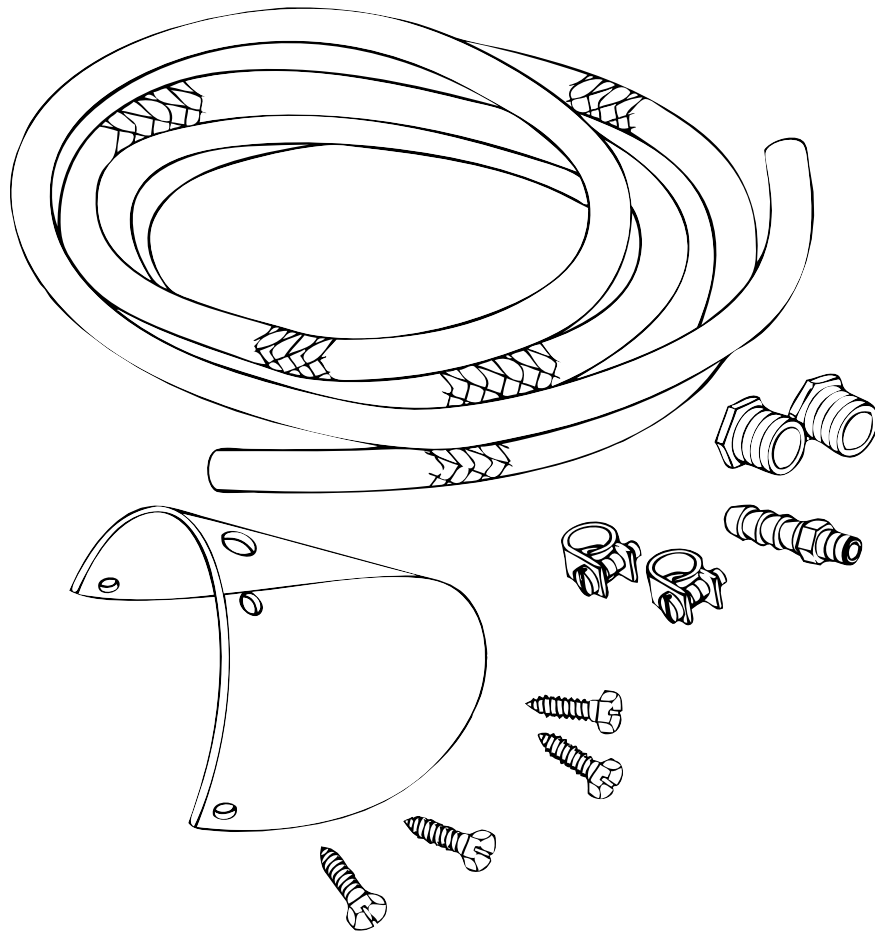

Shaft Diameter	Water Hose I.D.	Kit Part No.
3/4" thru 7/8"	1/4"	IXU-0750
1" thru 1-3/4"	1/4"	IXU-1000
2" thru 2-3/4"	1/4"	IXU-2000
3"	1/4"	IXU-3000
3" thru 3-3/4"	3/8"	IXU-3000A/IXU-3250
4" thru 4-3/4"	3/8"	IXU-4000
5" thru 5-3/4"	3/8"	IXU-5000
6" thru 6-3/4"	3/8"	IXU-6000

Shaft Size	A	B	C	Notes
DXU 0750 thru 0875	8-1/2	3-1/2	2	1-7/8
DXU 1000 thru 1750	8-15/16	4-1/2	2	2-3/8
DXU 2000 thru 2750	9-15/16	5-1/2	3-1/4MAX*	2-7/8
DXU 3000 thru 3750	11-13/16	7	3-1/4MAX*	3-5/8
DXU 4000 thru 4750	12	8	3-1/4	4-1/8
DXU 5000 thru 5750	12-5/16	10	3-1/4	5-1/8
DXU 6000 thru 6750	12-5/16	11	3-1/4	5-5/8

SXU Stern Tube Clamp Adapters

To determine which stern tube clamp adapter to order, measure the propeller shaft and stern tube diameters. Match the diameters on the adjacent chart to determine the part number.

If your size is not listed, please call Duramax Marine at 440-834-5400

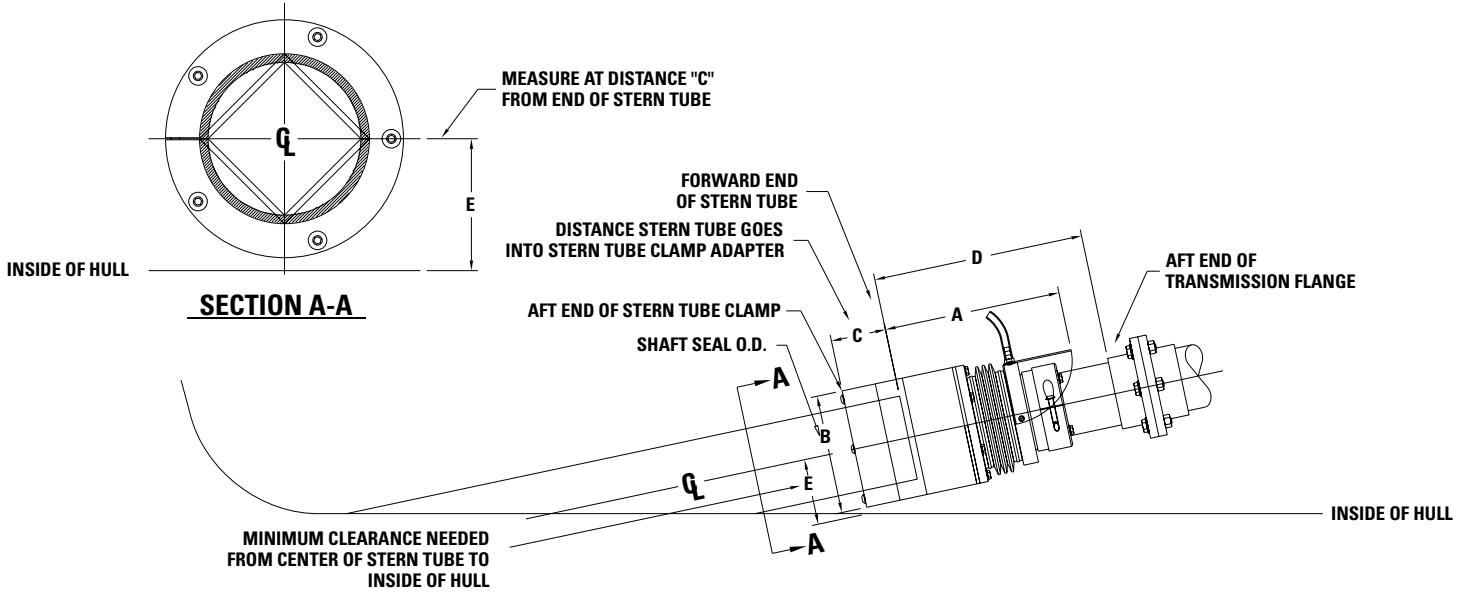

Shaft Diameter	Stern Tube Diameter	Adapter Part Number
3/4" thru 7/8"	1-1/2"	SXU-0750-1500
3/4" thru 7/8"	1-5/8"	SXU-0750-1625
3/4" thru 7/8"	1-3/4"	SXU-0750-1750
1"	1-1/2"	SXU-1000-1500
1" thru 1-1/4"	1-3/4"	SXU-1000-1750
1" thru 1-1/4"	2"	SXU-1000-2000
1" thru 1-1/4"	2-1/4"	SXU-1000-2250
1" thru 1-3/8"	2"	SXU-1000-2000A
1" thru 1-3/4"	2-3/8"	SXU-1000-2375
1" thru 1-3/4"	2-1/2"	SXU-1000-2500
1" thru 1-3/4"	2-5/8"	SXU-1000-2625
1" thru 1-3/4"	2-3/4"	SXU-1000-2750
1" thru 1-3/4"	2-7/8"	SXU-1000-2875
1" thru 1-3/4"	2-15/16"	SXU-1000-2938
1" thru 1-3/4"	3"	SXU-1000-3000
2"	2-3/4"	SXU-2000-2750
2" thru 2-1/4"	2-7/8"	SXU-2000-2875
2" thru 2-1/4"	3"	SXU-2000-3000
2" thru 2-1/2"	3-3/8"	SXU-2000-3375
2" thru 2-3/4"	3-1/2"	SXU-2000-3500
2" thru 2-3/4"	3-5/8"	SXU-2000-3625
2" thru 2-3/4"	3-3/4"	SXU-2000-3750
2" thru 2-3/4"	3-7/8"	SXU-2000-3875
2" thru 2-3/4"	4"	SXU-2000-4000
2" thru 2-3/4"	4-1/2"	SXU-2000-4500
2" thru 2-3/4"	5"	SXU-2000-5000
3" thru 3-1/4"	4"	SXU-3000-4000
3" thru 3-3/4"	4-1/2"	SXU-3000-4500
3" thru 3-3/4"	5"	SXU-3000-5000
3" thru 3-3/4"	5-9/16"	SXU-3000-5563
3-1/2"	6"	SXU-3500-6000
4" thru 4-3/4"	6"	SXU-4000-6000
5"	6"	SXU-5000-6000

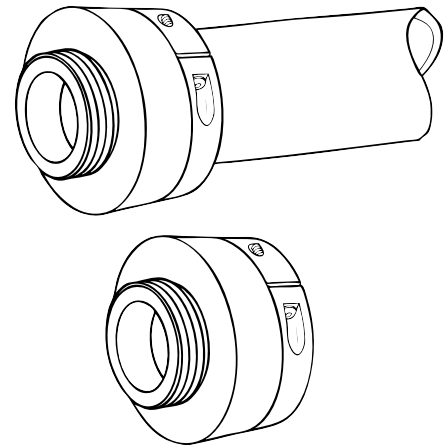

Shaft Size	A	B	C	Notes
DXU 0750 thru 0875	8-1/2	3-1/2	2	1-7/8
DXU 1000 thru 1750	8-15/16	4-1/2	2	2-3/8
DXU 2000 thru 2750	9-15/16	5-1/2	3-1/4MAX*	2-7/8
DXU 3000 thru 3750	11-13/16	7	3-1/4MAX*	3-5/8
DXU 4000 thru 4750	12	8	3-1/4	4-1/8
DXU 5000 thru 5750	12-5/16	10	3-1/4	5-1/8
DXU 6000 thru 6750	12-5/16	11	3-1/4	5-5/8

HXU Hose Adapters

To determine which hose adapter to order, measure the propeller shaft and stern tube diameters. Match the diameters on the adjacent chart to determine the part number.

If your size is not listed, please call Duramax Marine at 440-834-5400

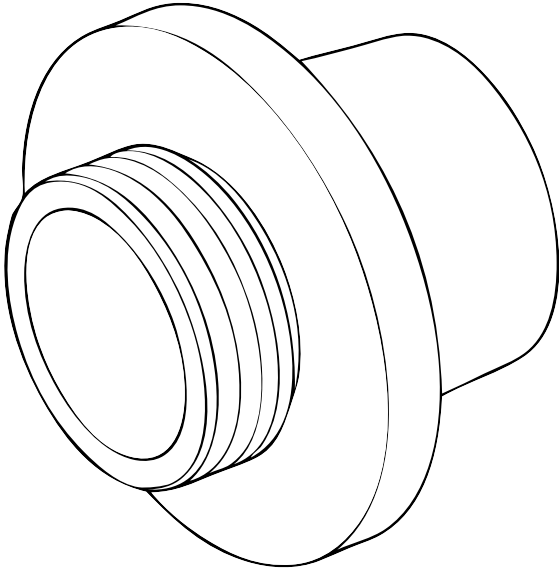

Shaft Diameter	Stern Tube Diameter	Adapter Part Number
3/4" thru 7/8"	1-1/2"	HXU-0750-1500
3/4" thru 7/8"	1-3/4"	HXU-0750-1750
1" thru 1-1/8"	1-3/4"	HXU-1000-1750
1" thru 1-1/4"	2"	HXU-1000-2000
1" thru 1-1/2"	2-1/4"	HXU-1000-2250
1" thru 1-3/4"	2-3/8"	HXU-1000-2375
1" thru 1-3/4"	2-1/2"	HXU-1000-2500
1" thru 1-3/4"	2-5/8"	HXU-1000-2625
1" thru 1-3/4"	3"	HXU-1000-3000
1" thru 1-3/4"	3-1/2"	HXU-1000-3500
2"	2-3/4"	HXU-2000-2750
2" thru 2-1/4"	2-7/8"	HXU-2000-2875
2" thru 2-1/4"	3"	HXU-2000-3000
2" thru 2-3/4"	3-1/2"	HXU-2000-3500
2" thru 2-3/4"	4"	HXU-2000-4000
2" thru 2-3/4"	4-1/4"	HXU-2000-4250
2" thru 2-3/4"	4-1/2"	HXU-2000-4500
2" thru 2-3/4"	5"	HXU-2000-5000
3" thru 3-1/4"	4"	HXU-3000-4000
3" thru 3-3/4"	4-1/2"	HXU-3000-4500
3" thru 3-3/4"	5"	HXU-3000-5000
4"	5"	HXU-4000-5000
4" thru 4-3/4"	5-1/2"	HXU-4000-5500
4" thru 4-3/4"	6"	HXU-4000-6000
4" thru 2-3/4"	7"	HXU-4000-7000
5"	6"	HXU-5000-6000
5" thru 5-1/2"	6-1/2"	HXU-5000-6500
5" thru 5-3/4"	7"	HXU-5000-7000
6"	7"	HXU-6000-7000
6" thru 6-1/2"	7-1/2"	HXU-6000-7500
6" thru 6-3/4"	8"	HXU-6000-8000

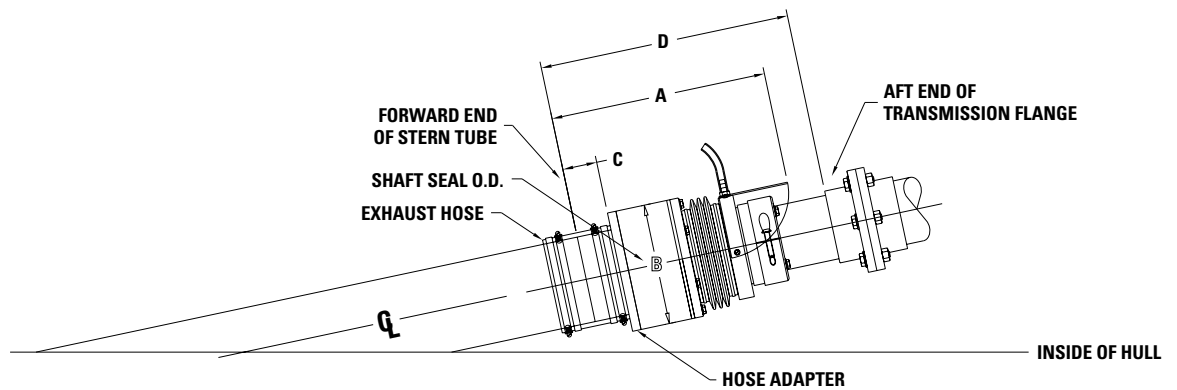

Shaft Size	A	B	C	Notes
DXU 0750 thru 0875	10-3/4	3-1/2	2	
DXU 1000 thru 1750	11-3/16	4-1/2	2	
DXU 2000 thru 2750	11-15/16	5-1/2	2	
DXU 3000 thru 3750	13-15/16	7	2	
DXU 4000 thru 4750	15-1/8	8	3	
DXU 5000 thru 5750	16-1/16	10	3	
DXU 6000 thru 6750	16-1/16	11	3	

FXU Flange Adapters

The flange adapter is used for new construction and for major overhauls or retrofit.

If your size is not listed, please call Duramax Marine at 440-834-5400

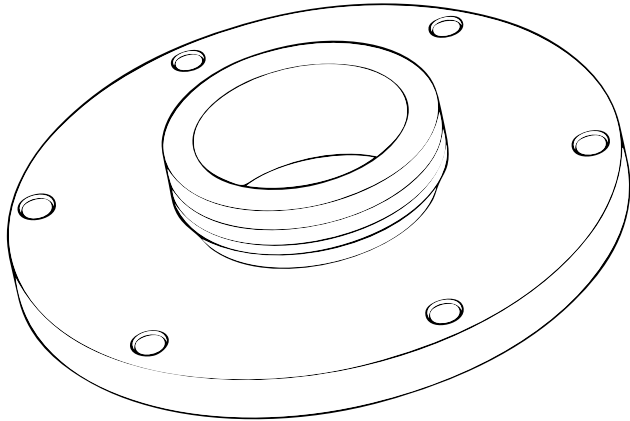

Shaft Diameter	Flange Diameter	Adapter Part Number
3/4" thru 7/8"	5"	FXU-0750-THR
1" thru 1-3/4"	6"	FXU-1000-THR
2" thru 2-3/4"	8"	FXU-2000-THR

Shaft Diameter	Flange Diameter	Adapter Part Number
3" thru 3-3/4"	9"	FXU-3000-BOLT
4" thru 4-3/4"	10"	FXU-4000-BOLT
5" thru 5-3/4"	12-1/2"	FXU-5000-BOLT
6" thru 6-3/4"	13-1/2"	FXU-6000-BOLT

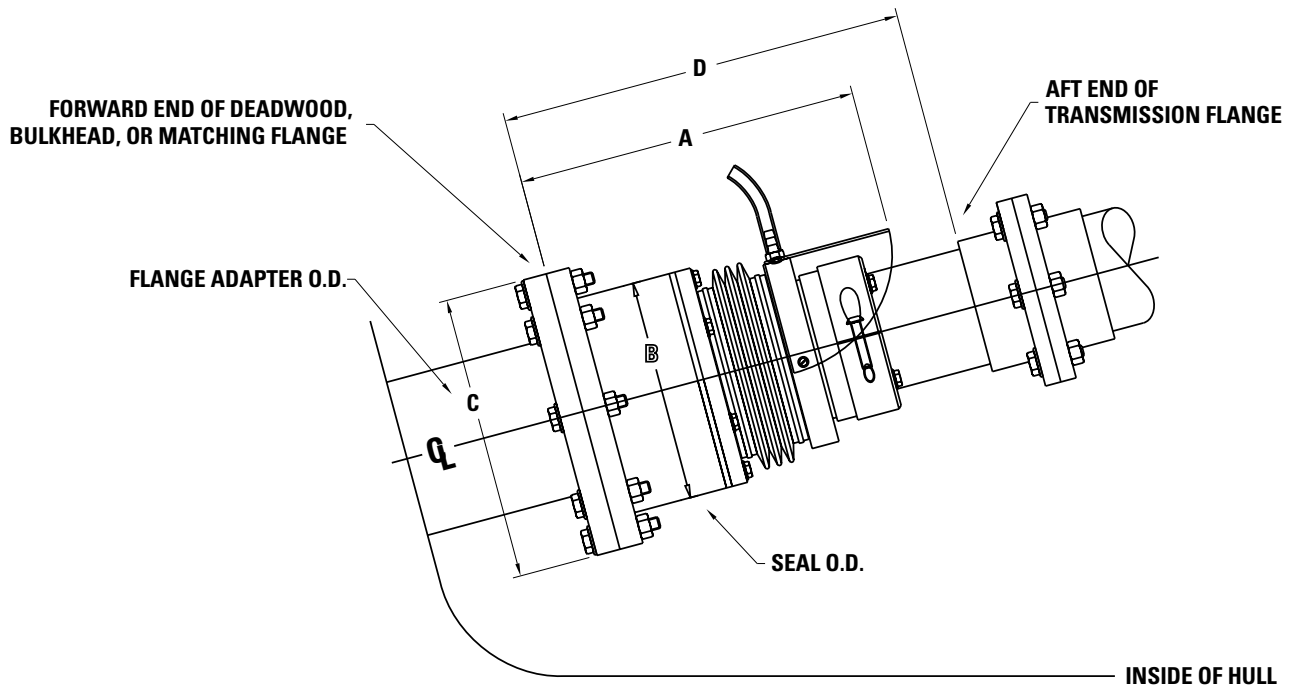

Shaft Size	A	B	C	Notes
DXU 0750 thru 0875	8-3/4	3-1/2	5	
DXU 1000 thru 1750	9-3/16	4-1/2	6	
DXU 2000 thru 2750	9-15/16	5-1/2	8	
DXU 3000 thru 3750	11-15/16	7	9	
DXU 4000 thru 4750	12-1/8	8	10	
DXU 5000 thru 5750	13-1/16	10	12-1/2	
DXU 6000 thru 6750	13-1/16	11	13-1/2	

TXU Thru-hull Adapters

The thru-hull adapter is used for new construction and for major overhauls or retrofit.

If your size is not listed, please call Duramax Marine at 440-834-5400

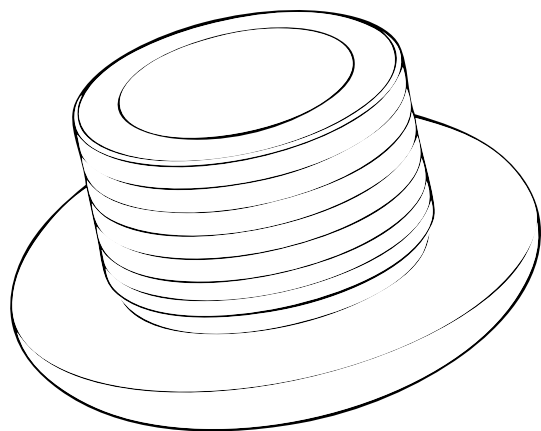

Shaft Diameter	Adapter Part Number Diameter
3/4" thru 7/8"	TXU-0750
1" thru 1-3/4"	TXU-1000
2" thru 2-3/4"	TXU-2000
3" thru 3-3/4"	TXU-3000
4" thru 4-3/4"	TXU-4000
5" thru 5-3/4"	TXU-5000
6" thru 6-3/4"	TXU-6000

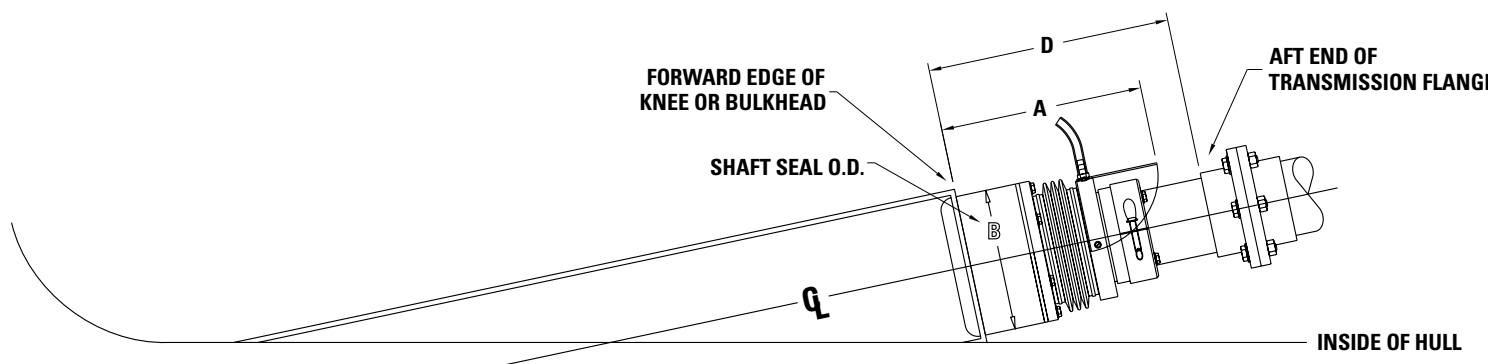

Shaft Size	A	B	Notes
DXU 0750 thru 0875	8-1/4	3-1/2	
DXU 1000 thru 1750	8-11/16	4-1/2	
DXU 2000 thru 2750	9-7/16	5-1/2	
DXU 3000 thru 3750	11-7/16	7	
DXU 4000 thru 4750	11-5/8	8	
DXU 5000 thru 5750	12-5/16	10	
DXU 6000 thru 6750	12-5/16	11	

INNOVATION.
EXPERIENCE.
RESULTS.

Duramax Marine® is committed to providing excellence in every product we manufacture. Our Johnson Cutless® marine and industrial bearings, heat exchangers, impact protection systems and sealing systems are known worldwide for their engineered quality and dependable performance. Please contact the factory for information on any of the following Duramax Marine® products:



JOHNSON CUTLESS® WATER-LUBRICATED BEARING SYSTEMS

Johnson Cutless® Sleeve and Flanged Bearings

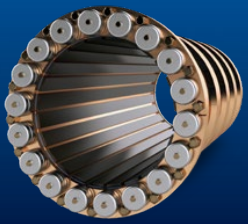

DURAMAX® ADVANCED WATER-LUBRICATED BEARING SYSTEMS

Johnson® Demountable Stave Bearings
ROMOR® I Stave Bearings and Segmental Housings
ROMOR® C- Partial Arc Bearings
DMX® Polymer Alloy Bearings
DuraBlue® Bearings, Rudder & Pintle Bushings, Thrust Washers, and Wear Pads
Industrial Pump Bearing Systems



DURAMAX® HEAT EXCHANGE SYSTEMS

DuraCooler® Keel Coolers
Duramax® Demountable Keel Coolers
Duramax® BoxCoolers

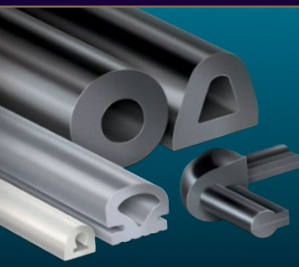

DURAMAX® IMPACT PROTECTION SYSTEMS

Johnson® Commercial Dock Bumpers, Fenders & Tow Knees
LINERITE® Composite Batterboard Systems



DURAMAX® SHAFT SEALING SYSTEMS

DryMax® Shaft Seal & Rudder Seal
Duramax® Mechanical Shaft Seal
Johnson® Heavy-Duty Air Seal Stuffing Boxes
Duramax® Ultra-X® High Performance Compression Packing

©2023 Duramax Marine®
17990 Great Lakes Parkway
Hiram, Ohio 44234 U.S.A.
PHONE 440.834.5400
FAX 440.834.4950
info@DuramaxMarine.com
www.DuramaxMarine.com

Duramax Marine® is an ISO 9001:2015 Certified Company

DURAMAX MARINE®