

DURAMAX[®]

Box Cooler

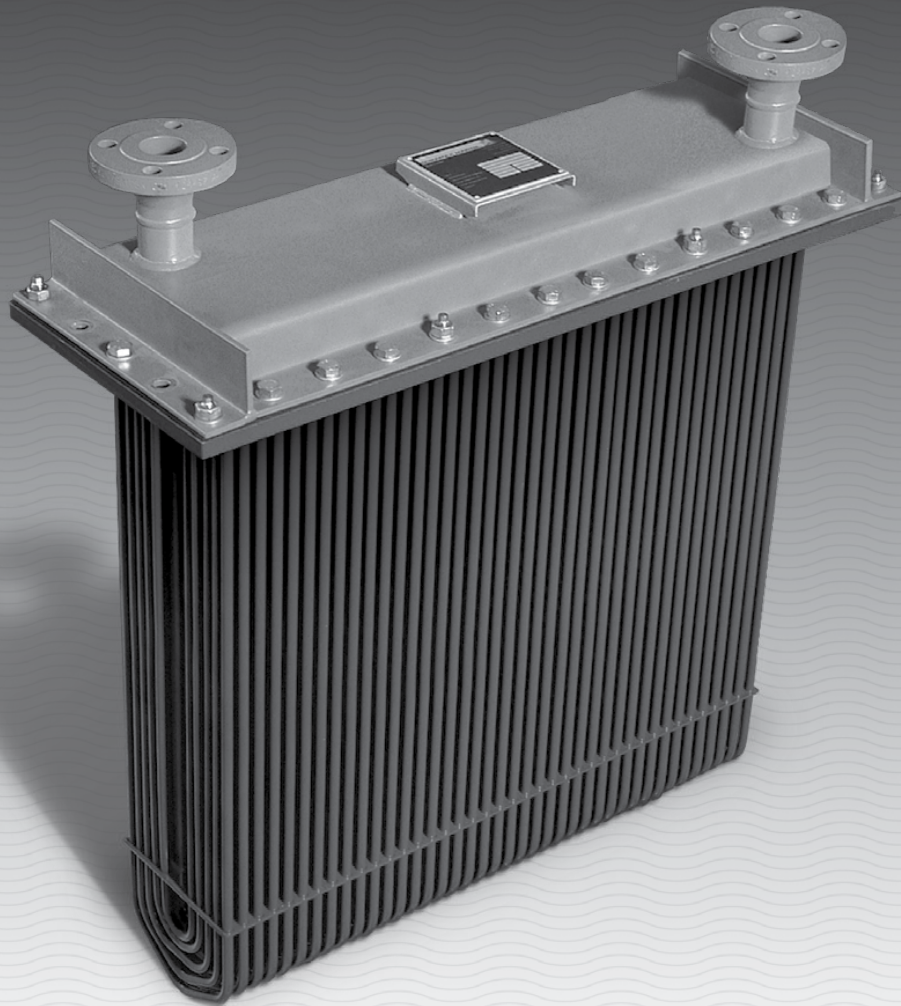

Installation Manual

Duramax Marine[®] is an ISO 9001:2015 Certified Company

DURAMAX MARINE[®]





Do not install, operate or service this box cooler without having read and fully understand all information enclosed in this manual.

INDEX

1.	INTRODUCTION.....	1
1.1.	Safety.....	1
2.	PRODUCT DESCRIPTION, INTENDED USE, WARRANTY	1
2.1.	Product description	1
2.2.	Intended use.....	2
2.3.	Warranty.....	3
2.4.	Type plates.....	3
3.	RECEIVING, HANDLING AND STORAGE	4
3.1.	Receiving.....	4
3.2.	Instructions for transport, handling and lifting	4
3.3.	Short and long term storage.....	4
4.	INSTALLATION.....	5
4.1.	Sea chest design	5
4.2.	Welding the mounting frame in position.....	6
4.3.	Mounting	7
4.4.	Fixing the process piping	11
4.5.	ICAF systems	13
5.	COMMISSIONING AND OPERATION	14
5.1.	Check the system for satisfactory installation	14
5.2.	Start-up and operation	14
5.3.	Shut-down	14
6.	INSPECTION, MAINTENANCE AND REPAIRS	15
6.1.	Inspection during operation	15
6.2.	Internal inspection and TUBE plugging.....	16
6.3.	Maintenance during each dry-docking period.....	17
6.4.	Ordering spare parts.....	18
7.	MALFUNCTIONS.....	19
8.	TECHNICAL SPECIFICATIONS.....	20

1. INTRODUCTION

This manual pertains to a Duramax Marine® BOX COOLER.

The manual contains instructions for a correct and safe installation, operation and maintenance of the box cooler.

- **Read this manual completely before starting any work on the box cooler and before using the box cooler.**¹
- **Follow all instructions in this manual. Failure to do so can result in injuries, defects, accelerated wear and other material damage.**
- **Make sure you understand this manual. Contact Duramax Marine® with any questions. Installation, operation or maintenance of the box cooler without understanding this manual can be dangerous and is a misuse of the box cooler.**
- **The manual is an integrated part of the box cooler. Therefore, keep this manual available near the box cooler for future reference and during the entire life cycle of the box cooler (e.g. for maintenance and troubleshooting).**

1.1. SAFETY

In the relevant sections the safety related items are indicated by a **safety alert symbol**.



This is the safety alert symbol

It is used to alert you to potential physical injury hazards.

- Obey all safety messages that follow these symbols to avoid possible injury.

Severe water leakage

The mounting frame and the tube bundle are part of the vessel's hull.

- **Do not remove the (collar) bolts or the tube bundle when the vessel is afloat!**

¹ Besides this manual, also the installation manual of the ICAF system may be supplied with the box cooler. Study this manual as well and follow all relevant instructions.

2. PRODUCT DESCRIPTION, INTENDED USE, WARRANTY

2.1. PRODUCT DESCRIPTION

The purpose of a box cooler is to dissipate heat caused by various processes on board of the ship.

The box cooler tubes are positioned inside a sea chest with inlet and outlet slots for outboard water.

The U-tube bundle is therefore surrounded by water (see fig. 1a).

Engine cooling water (or other liquid that needs to be chilled) is pumped through the tubes of the box cooler and chilled by the forced circulation of outboard water when the vessel is sailing. This eliminates the entire secondary raw water cooling system (pumps, filters, valves, piping, etc.).

When the vessel is in idle position, water circulation in the sea chest is caused by natural circulation. Natural circulation is caused because of the differences in the specific mass of water due to a temperature gradient.

Instead of one section, the box cooler may also be executed with two or three sections (see fig. 12b).

The aluminium brass tubes can be coated with a heat cured duroplast coating. This prevents galvanic corrosion of the carbon steel sea chest (which is the less noble metal) in seawater.

The heat cured duroplast coating also helps to prevent stray currents and protects the box cooler from under-deposit corrosion, which can develop under marine fouling or other deposits.

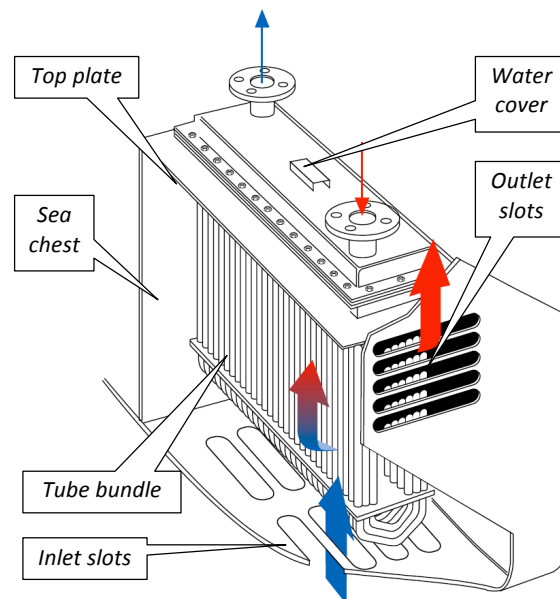



Figure 1a. Transverse mounted box cooler.

2.3. WARRANTY

See attached copy of Duramax Marine® terms and conditions of sale.

2.4. TYPE PLATES

The type plate of the box cooler shows the design limits on which the safe use of the box cooler depends. Below a typical example of a type plate for a box cooler is shown.

DURAMAX MARINE[®] LLC 

BoxCooler

17990 Great Lakes Parkway
Hiram, Ohio 44234 USA
440-834-5400
www.duramaxmarine.com

1 Tag No.

2 Manufacturing No.

3 Manufacturing Year/Weight (kg)

4 Design Temperature (°C)

5 Design/Test Pressure (barg)

6 Volume (L)

The numbers refer to:

- 1 Tag no. indicated by the customer.
- 2 Product number and manufacturing number.
- 3 Year of manufacturing and the total weight of the box cooler in kg.
- 4 The minimum / maximum design temperature. Refer to the attached technical specifications for the values.
- 5 The minimum / maximum design pressure in barg³. Refer to the attached technical specifications for the values. Usually the design pressure is 3 barg and the test pressure 5 barg.

The design pressure is the setpoint for the pressure limiting device (see section 4.4.2).

- 6 The volume of the box cooler in L (litre).

If a multiple section box cooler is supplied, items 4, 5, and 6 are shown for each section.

³ barg = *bar gauge* or overpressure, e.g. 0 bar(a) = -1 bar g.

3. RECEIVING, HANDLING AND STORAGE

3.1. RECEIVING

- The box cooler is usually delivered in a wooden case. Carefully open the case upon receipt and check if all items are present (check against the bill of lading) and inspect all items for damage.
- Note any damage or missing items on the carrier's bill of lading and file a claim immediately with the freight company. When possible, take pictures of the damage.
- Notify Duramax Marine® immediately when damage is observed or when items are missing.
- Close the case immediately after inspection, to avoid that the items in the case get lost or damaged.
- Leave the box cooler inside the case until immediately before installation.

3.2. INSTRUCTIONS FOR TRANSPORT, HANDLING AND LIFTING

 **Heavy loads**

Crushing or severe personal injury caused by a falling or swinging load due to incorrect handling or lifting.

- Transportation, handling or lifting of the box cooler shall only be carried out by suitably trained and qualified personnel.
- Use lifting equipment with adequate lifting capacity and appropriate lifting accessories with hooks and shackles that are suitable for the lifting provisions.

 ➤ Stand clear of load.

 ➤ Wear safety helmet and safety shoes.

- Lift the tube bundle only by four M16 eyebolts⁴ (DIN 580). Tighten them into the 4 threaded holes in the tube sheet which are designated for this. If needed the position of the eyebolts must be adjusted with suitable washers. Do not insert the point of a hook in an eyebolt but use a shackle. Lift only by using all 4 eyebolts simultaneously (see fig. 2). Do not insert the point of a hook in an eyebolt but use a shackle.

- Lift the water cover only by the 4 lifting holes provided in the end plates (see fig. 2).
- **Pay attention to the weight.** The weight of the box cooler is shown in the technical specifications at the end of this manual and on the type plate.
- Do not use nozzles, flanges or other protruding parts to move or lift the box cooler.
- **Prevent damage to the box cooler, especially the duroplast coating.** A damaged coating (also small damages) will lead to accelerated (galvanic) corrosion. Small damages can be touched up by a special two-component repair set, which can be ordered from Duramax Marine®.
- Prevent impacts and dropping.
- Pay attention to the centre of gravity, do not swing, cant or tilt.

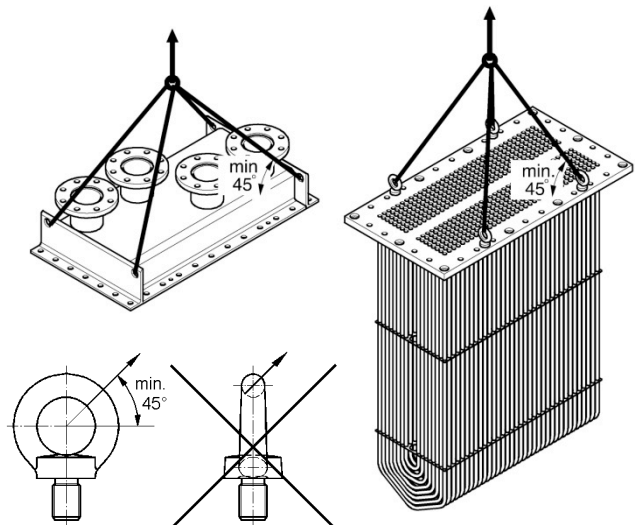

Figure 2. Lifting of the water cover and the tube bundle.

3.3. SHORT AND LONG TERM STORAGE

The box cooler may need to be stored for a longer period of time prior to installation.

- Leave the box cooler inside the wooden case in which it is supplied to protect it against damage.
- Store the case in a dry, well-ventilated area, protected from the weather, preferably indoors.
- Avoid wide temperature fluctuations to prevent that condensation and moisture enter in the box cooler.
- Do not stack other objects on top of the case.
- Do not use the case as a climbing aid

⁴ The eyebolts are not part of the scope of supply from Duramax Marine®.

4. INSTALLATION



Unsafe operation

Improper installation or installation performed by incompetent or unqualified personnel may result in unsafe operation, defects and accelerated corrosion.

- Installation of the box cooler shall only be carried out by suitably trained, qualified and instructed engineers, welders and electricians.

The installation of the box cooler consists of the following steps:

1. Designing and preparing the sea chest.
2. The welding of the mounting frame
3. Installation of the tube bundle and the water cover
4. Preparation and installation of the piping system, including the selection and installation of safety devices to prevent overpressure and overheating.
5. Electrical installation of the (optional) ICAF system.

4.1. SEA CHEST DESIGN

The box cooler may be arranged in either athwartship or longitudinal position:

1. **Transversely (athwartships):** this is the most common way to mount a box cooler. The box cooler is mounted between the existing frames of the vessel (see fig. 3a).
2. **Longitudinally (parallel with fore and aft centerline):** this method is less popular as the frames have to be cut open to allow the special sea chest to be installed (see fig. 3b).
3. Ensure that the top plate of the sea chest is on or below the waterline when the ship is empty. This is to make sure that the tube bundle is fully surrounded by (sea) water at all times.
4. Ensure adequate ventilation of the sea chest to prevent that air is trapped inside the sea chest which reduces the heat transfer. Suggested is to weld a thick walled pipe into the top plate with a minimum inside diameter of 70 mm.
5. Maintain a minimum free space of 80 mm between tube bundle and any part of the ship's construction for a coated box cooler and 100mm for an uncoated box cooler.

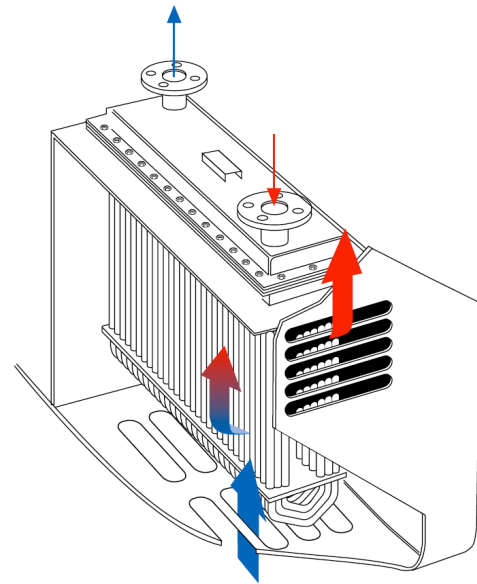

Figure 3a. Transverse mounting.

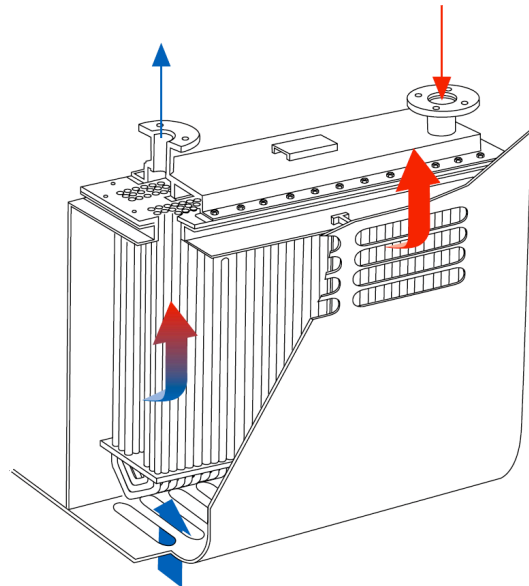

Figure 3b. Longitudinal mounting.

6. The seawater inlet slots are to be situated in the base of the sea chest and positioned transversely (athwartships).
7. The seawater outlet slots are to be situated in the outer wall of the hull and positioned longitudinally (parallel with fore and aft centerline) directly under the top surface of the sea chest, but must remain below the waterline when the vessel is empty.
8. The number of slots is dependant upon various factors such as speed, service, shape, etc.

The width of each opening is 50 mm but the length depends on the frame spacing of the ship. A typical slot opening in a hull is 50 x 400 mm = 20,000 mm² or 2 dm².

For a high temperature (HT) circuit, provide **6 dm² of inlet slots per 100 kW** heat rejection.

For a low temperature (LT) circuit, provide **9 dm² of inlet slots per 100 kW** heat rejection.

The area of the **outlet slots** should be **80%** of the inlet slots.

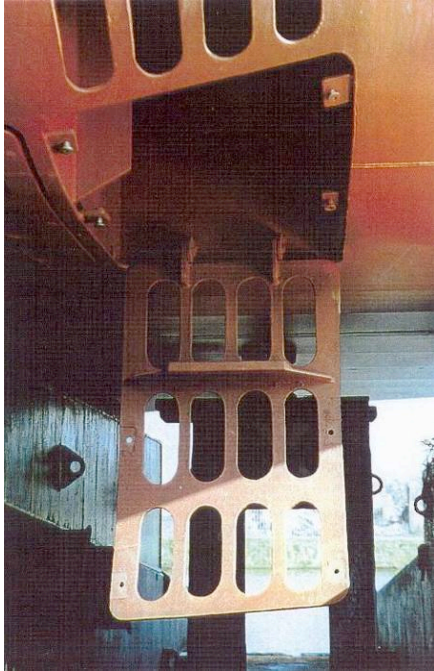

Figure 4. Examples of inlet slots in a hatch (to be used as inspection opening/man hole).

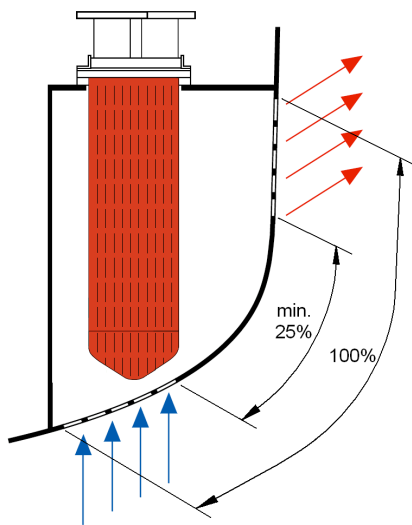

Figure 5. Maintain a closed area between the inlet and outlet slots of at least 25% of the hull section.

9. In case these slots are not possible, make as many openings as possible. Position (sea) water inlet slots as low as possible and outlet slots as high as possible. Assure a closed sea chest surface between the inlet

and outlet slots of at least 25% of the total tube length (see fig. 5).

When in doubt contact Duramax Marine® for advice and send a drawing of the sea chest.

10. All materials for the sea chest, including the top plate and the (supplied) mounting frame, should have at least equal thickness as the rest of the ship's plating.
11. The tube bundle is made of copper alloys. These metals are more noble than the carbon steel sea chest. Without proper protection, this may cause severe galvanic corrosion of the sea chest due to galvanic currents between the tube bundle and the sea chest, where the (sea) water serves as an electrolyte.

To protect the sea chest from galvanic corrosion **all metal areas of the sea chest shall be well preserved.** Furthermore, it is highly recommended to **install sacrificial anodes.**
12. Make sure that the space above the box cooler allows for sufficient access to carry out installation, inspection, cleaning and maintenance (see also section 6).

Top mounted box coolers also require sufficient space for installation and retraction of the tube bundle.

4.2. WELDING THE MOUNTING FRAME IN POSITION

After welding the mounting frame is part of the ship's hull. All reinforcements, stiffeners, hull material and thicknesses are to be defined by the yard.

All welding shall be carried out according to the applicable requirements of the Classification Society's Rules.

Recommended is for T-joints to use double bevel T-butt welds (see fig. 9 and 10) to minimize distortion.

Avoid damage to the box cooler. Do not weld on or near the mounting frame when the box cooler is installed.

If a mounting frame is not part of the order, use the bolt pattern of the water cover as a drilling template.

- 1) Move the wooden crate with the box cooler and all related parts to area where the sea chest is located.
- 2) Take the carbon steel mounting frame out of the wooden case (note that alternative configurations exist, see section 4.3.1, 4.3.2 and 4.3.3).

- 3) Close the case after taking out the mounting frame to avoid that the remaining parts in the case get lost or damaged.
- 4) Position the mounting frame on/in the opening of the top plate of the sea chest.
- 5) First tack-weld the frame into position to minimize deformation during final welding (see fig. 6).

Check the flatness. The maximum flatness deviation after welding is 3 mm. Too much deformation may cause leakage as it is not possible to make a water tight connection.

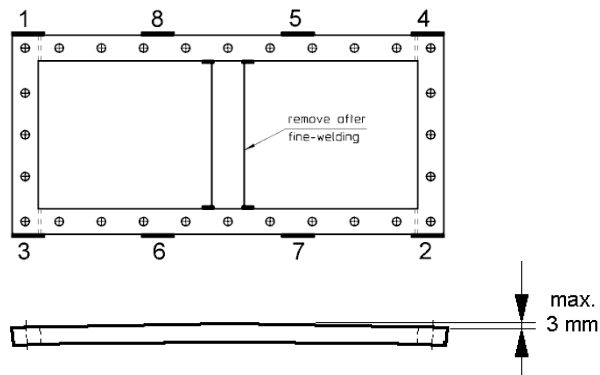

Figure 6. Welding of the mounting frame.

- 6) Complete the final weld. Make sure the tack welds do not interfere with the smooth completion of the final weld.
- 7) **After welding, the mounting frame and sea chest shall be suitably coated.**

Protect the tube bundle against paint!

Do not coat the cathode plates of the ICAF system!
(when applicable)

4.3. MOUNTING

The box cooler can be mounted in two different ways:

- From above (top-mounted), see section 4.3.1.
- From below (bottom-pull), see section 4.3.2.

Bottom-pull mounted box coolers are optional supplied with a header frame instead of a separate mounting flange (see section 4.3.3).

Fig. 7 shows an exploded view of a top mounted box cooler and fig. 8a a cross section detail.

The **collar bolts** are used to fix the tube bundle to the mounting frame. This allows for removal of the water cover without loosening the tube bundle.

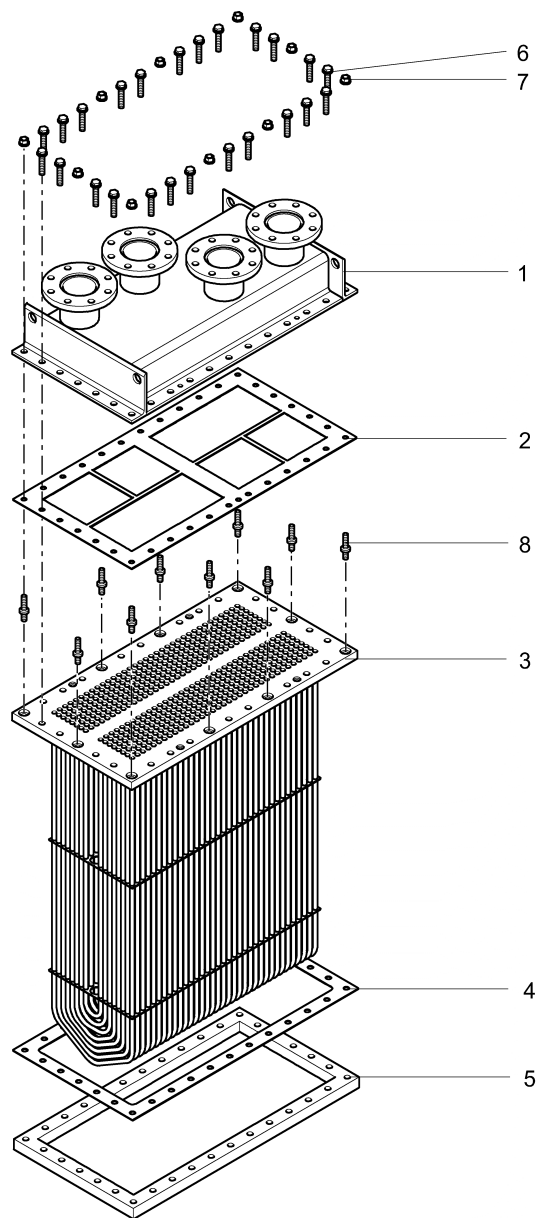

- 1 Water cover
- 2 Gasket between water cover and tube bundle
- 3 Tube bundle
- 4 Gasket for mounting frame⁵
- 5 Mounting frame (welded in the sea chest)
- 6 Bolt (standard hexagonal)
- 7 Nut
- 8 Collar bolt

Figure 7. Exploded view of the box cooler (top mounted).

⁵ Both gaskets are made of SBR (Styrene-Butadiene rubber).

4.3.1. Top mounting of the tube bundle

- 1) Take the tube bundle with the mounting materials out of the wooden case (see the lifting instructions of section 3.2). Close the case to avoid that the remaining parts in the case get lost or damaged.
- 2) Inspect the tube bundle thoroughly before installation. Transportation and rough handling may have caused damage to the piping or the coating. Contact Duramax Marine® when damage is observed.
- 3) Clean the gasket faces and make sure they are free of defects (burrs, pits, dents, etc.).
- 4) Position the mounting frame gasket (item 5 of fig. 8a) on the mounting frame.

Make sure the gasket is clean.

Do not use sealant, grease, glue or any other agent when installing the SBR gasket.

- 5) Carefully lower the tube bundle into the sea chest.

Do not to damage the tubes and the coating. A damaged coating may reduce the lifetime of the box cooler and will-accelerate galvanic corrosion of the sea chest!

- 6) Position the supplied collar bolts in the appropriate bolt holes of the tube plate and fasten hand tight (see fig. 8a).
- 7) Tighten collar bolts alternate and crosswise (see section 4.4.4) with a torque wrench to guarantee an even setting of the gaskets.

Refer to section 4.4.4 for tightening torques.

Note that the collar bolts must ensure a watertight sealing when the water cover is removed.

- 8) When the collar bolts are tightened, the water cover can be mounted.

Continue with section 4.4.

Besides top mounting, there are two other methods for installation of the box cooler. These are described in the next two sections.

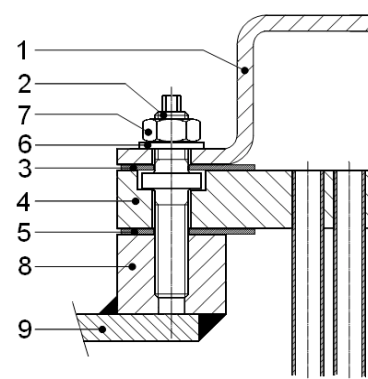

- 1 Water cover
- 2 Collar bolt
- 3 Gasket between water cover and tube bundle
- 4 Tube bundle
- 5 Gasket for mounting frame
- 6 Washer
- 7 Nut
- 8 Mounting frame into the top plate
- 9 Top plate of the sea chest

Figure 8a. Top mounting arrangement with collar bolt.

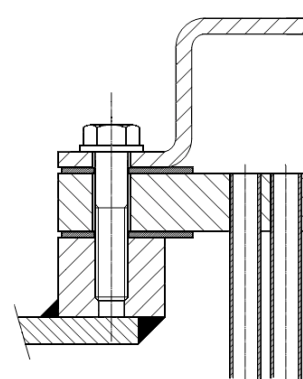

Figure 8b. Top mounting arrangement, standard bolts

4.3.2. Bottom-pull mounting method

When a box cooler for bottom-pull mounting is supplied, the tube bundle is mounted from below.

For that purpose a hatch is to be made in the ship's hull through which the tube bundle is brought into the sea chest (see fig. 4).

In that case two frames are supplied:

- Frame 1 is the mounting frame which is to be welded into the top plate of the sea chest (*item 1 of fig. 9a*)
- Frame 2 is used as an interface, to bolt the tube bundle to the mounting frame (*item 2 of fig. 9a*)

Fig. 9a shows the collar bolts and fig. 9b the standard bolts for the water cover.

- 1) Weld the mounting frame (frame 1) in position according to the instructions of section 4.2.
- 2) Take the tube bundle, frame 2, the gasket and the mounting materials out of the wooden case and inspect and clean the parts according to the instructions of section 4.3.1.
- 3) Position the gasket that is used between frame 2 and the tube sheet on top of frame 2. Make sure the gasket and the gasket faces are clean.

Do not use sealant, grease, glue or any other agent when installing the SBR gasket.

- 4) Fasten frame 2 to the tube sheet with the supplied collar bolts.
- 5) Position the gasket that is used between the mounting frame and the tube bundle on top of the tube sheet.
- 6) Lift the tube bundle by means of four M16 eyebolts (see fig. 2) from below into position. See lifting method "1" of fig. 10c.
- 7) Fasten the sub-assembly (tube bundle with frame 2) to the mounting frame by means of the supplied M12 bolts.

Refer to section 4.4.4 for tightening torques.

- 8) When the collar bolts are tightened, the water cover can be mounted.

Continue with section 4.4.

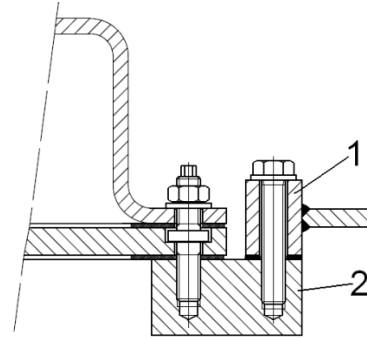

Figure 9a. Bottom-pull mounting arrangement with collar bolt.

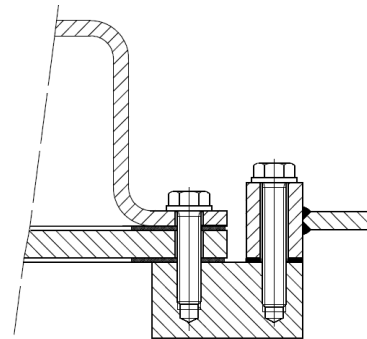

Figure 9b. Bottom-pull mounting arrangement with standard bolts.

4.3.3. Mounting by means of a header frame

The water cover can also be made out of two parts: a rectangular header frame (*item 2 of fig. 10a*) with a flat cover (*item 1 of fig. 10a*).

The rectangular header frame is directly welded into the top plate of the sea chest (according to the welding instructions of section 4.2). So in that case there is no (separate) mounting frame.

After the header frame is welded in the top plate, the tube bundle (*item 3 of fig. 10a*) is installed from below and the header from above.

Fig. 10a shows an Allen head screw (socket head cap screw) which remains in place when the cover is removed. Fig. 10b shows the standard bolts.

Note that the Allen head screws, like the collar bolts, must ensure a watertight sealing when the water cover is removed.

Assembly and installation of the tube bundle:

- 1) Take the tube bundle, the gasket and the mounting materials out of the wooden case and inspect and clean the parts according to the instructions of section 4.3.1.
 - 2) Position the gasket that is used between the header frame and the tube bundle on top of the tube sheet. Make sure the gasket and the gasket faces are clean.
- Do not use sealant, grease, glue or any other agent when installing the SBR gasket.**
- 3) Lift the tube bundle (refer to fig. 2) until just below the header frame, but leaving sufficient space to remove the eyebolts. (See "1" of fig. 10c.)
 - 4) Then take it over from the eyebolts using 4 long threaded rods with nuts. Insert 4 M12 threaded rods through the corners of the header frame and tighten them in the corresponding threaded holes of the tube sheet.

Secure the tube bundle by putting nuts on the threaded rods.

- 5) Now the eyebolts and the lifting gear can be removed.
- 6) Pull the tube bundle against the header frame. This can be done by fastening the 4 nuts evenly, or by putting 4 forged eyenuts (M12) on the threaded rods and lifting the bundle with a lifting devise.

Keep tightening the nuts during lifting to secure the position of the tube bundle.

- 7) Finally, fasten the tube bundle with the Allen head screws, see fig.10a.

The thread rods and the eyebolts and nuts are not part of the scope of supply from Duramax Marine®. The required length of the threaded rods is 0.5 to 1.0 m (depending on the size of the box cooler and the way the tube bundle is lifted).

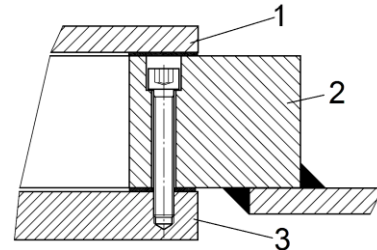

Figure 10a. Mounting arrangement with header frame (2), flat cover (1), tube sheet (3) and Allen head screw.

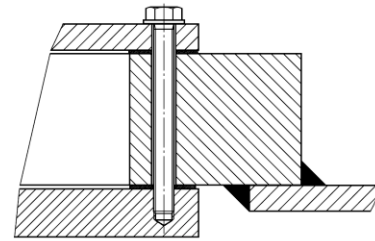

Figure 10b. Mounting arrangement with header frame, flat cover and a standard bolt.

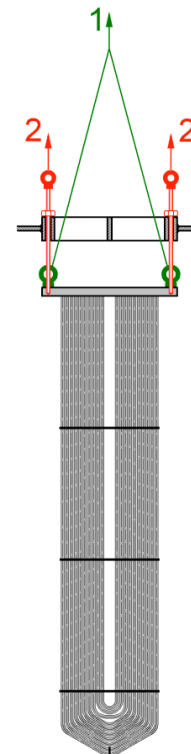

Figure 10c. Lifting the tube bundle towards the header frame in the top plate.

4.3.4. Mounting the water cover

- 1) Take the water cover with the gasket and the mounting materials out of the wooden case (see the lifting instructions of section 3.2).
- 2) Inspect the water cover before installation, especially the coating. Touch up when necessary.
- 3) Clean the gasket faces and make sure they are free of defects (burrs, pits, dents, etc.).
- 4) Position the supplied gasket between the water cover and the tube bundle (item 2 of fig. 7). Make sure the partitioning corresponds with the drawing and the water cover.

Make sure the gasket is clean.

Do not use glue, sealant, grease or any other sealing agent when installing the SBR gasket.

- 5) Carefully put the water cover in place. Check the orientation, refer to the supplied drawing.
Mind the weight. Take care not to damage the coatings, the gasket or the gasket faces.
- 6) Position the supplied bolts and the nuts for the collar bolts in the bolt holes and fasten hand tight (see fig. 8a and 8b).
- 7) Tighten all bolts and nuts alternate and crosswise with a torque wrench to guarantee an even setting of the gaskets.

Refer to section 4.4.4 for tightening torques.

The water cover can be painted on the outside.

Do not paint the inside of the water box. The paint may be stripped off by the fluid and blind the tubes.

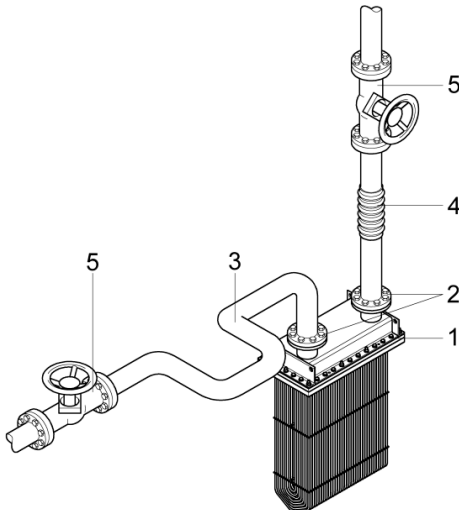

Figure 11. Typical piping installation with an expansion loop (3), an expansion joint (4) and service valves (5), connected to the box cooler flanges (1 and 2).

4.4. FIXING THE PROCESS PIPING

Ensure that all piping will be fixed to the box cooler without transferring load and (piping) vibrations to the box cooler.

Install safety devices to prevent overpressure and overheating (see section 4.4.2).

4.4.1. Piping design

- Ensure that the piping is well supported, **independently from the box cooler** and secured as close to the box cooler as possible.
- Avoid transferring piping vibrations to the heat exchanger. When needed, fit compensators which can absorb piping vibrations.
- Make sure the piping system allow for thermal expansion and contraction of both the box cooler and the attached piping. Ensure adequate flexibility of the piping system (e.g. by fitting expansion loops and expansion joints, see fig. 11).
Pipe supports should also allow for pipe movement.
- Prevent piping misalignment. This will cause increased nozzle loads. Note that the mentioned compensators and expansion joints also help to absorb some piping misalignment.
- Install adequate means for safe and complete draining and venting of the box cooler.

Fit air vents at high points to allow for system bleeding. System bleeding is required to ensure optimal heat transfer and to prevent fluid hammer. Venting is also required to enable complete drainage of the box cooler.

Draining is required to permit safe maintenance and, when applicable, to prevent freezing during shutdown periods (see section 5.3).

- Install manual service valves or bypasses in the supply and return pipes to enable isolation of the box cooler from the supply piping. In this way safe inspection and maintenance can be carried out without having to shut down or drain a larger system (see fig. 11).
- Install - when required - measuring devices to monitor the pressure, temperature and/or flow during operation. Fix the devices close to the box cooler to measure accurately.

4.4.2. Safety devices to be installed

Overpressure or overheating may cause the box cooler to leak, rupture or burst.

- 1) Fit a suitably sized and rated pressure limiting device (e.g. a pressure safety relief valve).

The set pressure must ensure that no part of the box cooler will experience pressure above the design pressure (see section 2.4).

- 2) Ensure suitable controls to prevent the maximum allowable temperature from being exceeded (if required by the process).

4.4.3. Connecting the piping to the box cooler

1. Make sure that the piping is clean before it is fixed to the nozzles so that no dirt or (metal) particles can enter the box cooler.
2. Remove all protective caps, plugs, shipping covers, etc., from the box cooler.
3. Make sure that all gasket faces of the flanges and all nozzle openings are clean and free of defects (burrs, pits, dents, etc.).
4. **Do not force the piping into alignment.** Make sure that the mating faces of the flanges of the box coolers and the piping are parallel to each other.
5. Use properly sized gaskets with the correct pressure class, suitable for the working temperatures and for all used fluids. Recommended are reinforced graphite ring gaskets.
6. Make sure the gaskets are properly centred and tighten up the stud bolts of the flanges alternate and crosswise to guarantee an even setting of the gaskets (see section 4.4.4).

4.4.4. Tightening torques

The bolts and nuts of the water covers and flanges need to be tightened during installation and maintenance or when joints are leaking.

Lubricate the threads of the bolt or stud, and the surface of the nut face adjacent to the flange or washer. Tightening of the bolts must be done “diagonally” with a torque wrench in at least four steps, see table 1 and fig. 12a, b, c and d.

In the case of leaking, the tightening torques may be increased by approximately 15%.

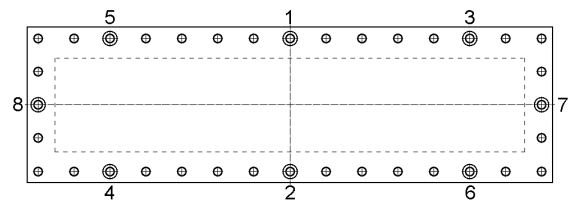

Figure 12a. Order of tightening of the collar bolts.

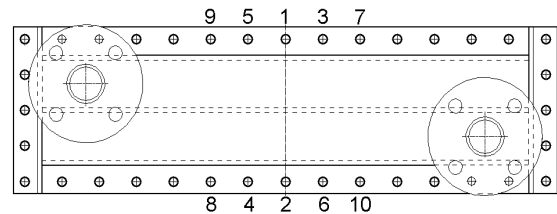

Figure 12b. Order of tightening of the bolts of the water cover of a single section box cooler. Start from the center.

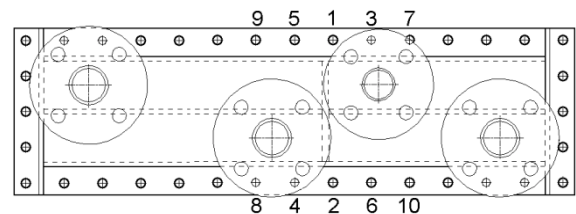

Figure 12c. Order of tightening of the bolts of the water cover of a double or triple section box cooler. Start from the (central) partition.

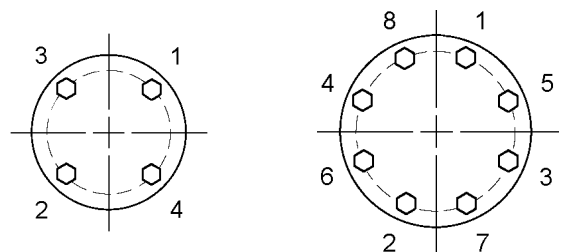

Figure 12d. Order of tightening of the bolts of the water covers and the flanges.

Size	Tightening torque [Nm]			
	Carbon steel, class 8.8 / ASTM A193 B7			
	Step 1	Step 2	Step 3	Step 4
M 12	25	45	65	85
M 16	60	110	165	215
M 20	130	230	330	430
M 24	200	400	575	740

Table 1. Recommended tightening torques (the values are base on "lightly lubricated bolts").

4.5. ICAF SYSTEMS

Box coolers may be affected by marine fouling (algae, mussels, barnacles and other shellfish) on the external surfaces of the tube bundle. In the long run this will seriously reduce the heat transfer.

This undesirable marine growth on the tube bundle can be reduced by installing an *Impressed Current Anti-Fouling* (ICAF) system.

An ICAF system is an electrolytic antifouling system. It consists of copper rods, the anodes, and carbon steel plates, which are mounted below the box cooler (see fig. 13).

A power unit in the engine room maintains a minor current (the *impressed current*) between the anodes and the cathodes in order to release the required minimum amount of copper ions. The copper ions mix with the seawater in the sea chest and de-regulate the local environmental balance, thus suppressing marine growth on the box cooler.

To simplify the installation, Duramax Marine® can supply the box cooler with an integrated ICAF system from Corrosion & Water Control (see fig. 14a).

In that case the copper anodes are clamped to a frame that is fixed to the box cooler. Each copper anode is provided with a 6 m cable. The cables are protected by tubes (conduits) and led through the tube sheet by means of cable glands (see fig. 14b).

Install the power unit and connect the cables according to the installation manual from *Corrosion & Water-Control bv* and observe all relevant instructions.

The electrical installation shall only be carried out by suitably qualified, capable and instructed electricians.

Do not coat the anode rods and cathode plates!

Note that the copper anodes are calculated for a specific dry-docking cycle (e.g. 3 or 5 years).



Figure 13. Copper rods (anodes) and steel (cathode) plates of the ICAF system mounted separately in the sea chest below the box cooler.

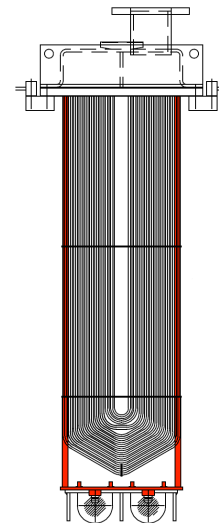

Figure 14a. Box cooler with integrated ICAF system.

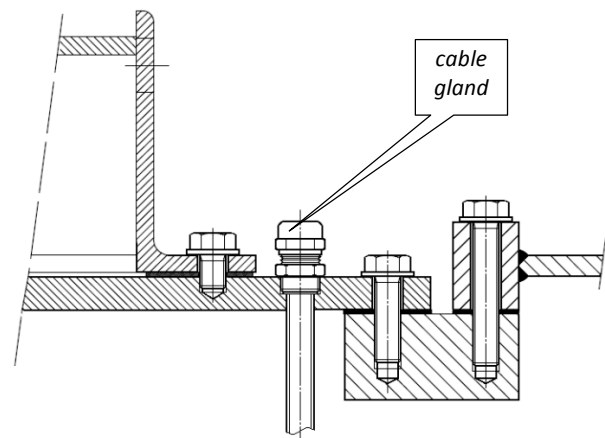

Figure 14b. Cable gland and conduit for the cables of the ICAF system, leading to the copper anodes.

5. COMMISSIONING AND OPERATION



Unsafe operation

Commissioning and operation by unqualified personnel may result in unsafe operation, defects and accelerated corrosion.

- The box cooler may only be commissioned and operated by suitably trained, qualified and instructed engineers and electricians.
- The box cooler may not be started or used before it is completely installed and inspected according to the instructions in this manual.
- Keep the operating conditions within the design limits.

5.1. CHECK THE SYSTEM FOR SATISFACTORY INSTALLATION

- Verify that all safety devices in the system (pressure limiting device, temperature control system) are correctly set and tested before start-up.
- Verify that all piping and pipe fittings are properly fixed and supported and allow for sufficient flexibility (see section 4.3.1).
- Check all bolted connections for tightness. Refer to section 4.4.4 for tightening torques. Verify also that no bolts or nuts are missing or broken.
- Check also the installation and working of the ICAF system (when applicable).

5.2. START-UP AND OPERATION

Do not use the box cooler outside of its specification range (operating pressure, operating temperature, flow speed, used fluids).

- 1) Open the vent valve and fill the box cooler gradually with the fluid for which it is designed. **Minimize stresses, ensure that the pressure rises slowly and the box cooler heats up evenly.**
- 2) Allow all air in the box cooler as well as from the whole system to escape then close the vent valve.
- 3) Allow the circuit to pressurize and open the return valve so the liquid can flow through.

- 4) Regularly carry out the inspections of section 6.1. **During the initial period of operation the system needs to be inspected more frequently.**



Shutdown the box cooler immediately in case of any possible defect, leakage or when the operating conditions are not within the design limits.

Investigate the cause (see section 7) and restart the box cooler only when all defects are fixed by a qualified maintenance engineer.

- 5) After the initial 8-10 hours of operation, shut the box cooler down (according to the instructions of section 5.3) and retighten all bolted connections (see section 4.4.4).

5.3. SHUT-DOWN

- 1) Stop the equipment that is cooled by the circulating liquid.
- 2) **Wait until the equipment has cooled down sufficiently.**
This is to prevent overheating of both the box cooler and the equipment that is cooled.
- 3) Stop the circulation of the liquid.

Drain during shutdown to avoid freezing

The medium will expand when it freezes and this may cause the tubes of the box cooler to burst and the water covers to become deformed.

Therefore drain the system when freezing is expected during shutdown. Blow the water out of the tubes using compressed air.

When a suitable amount of antifreeze is added to the stagnant liquid, the box cooler does not require to be drained. (Note that the adding of antifreeze to the cooling water may have consequences for the performance of the box cooler. Check the technical specifications or contact Duramax Marine® for advice.)

Alternatively, keep the liquid circulating if the system must be left full.

6. INSPECTION, MAINTENANCE AND REPAIRS



Unsafe operation

Insufficient or improper inspection and maintenance, or inspection and maintenance carried out by incompetent or unqualified personnel, may result in unsafe operation, defects and accelerated corrosion.

- Inspection, maintenance and repairs of the box cooler shall only be carried out by suitably trained, qualified and instructed engineers and electricians.
- Draw up a schedule for regular inspection, maintenance and cleaning.
- Immediately repair or correct each malfunction, defect or fault that may generate a hazard.

Safe and sustainable operation and good performance can only be retained if regular inspection and maintenance is carried out.

Inspection and maintenance/repair consists of:

1. Regular inspections during operation
2. Internal inspection of the tube bundle and plugging of tubes when a tube is leaking
3. External inspection and cleaning of the tube bundle and the sea chest every dry-docking period
4. Cleaning / replacing the ICAF anodes, every dry-docking period (if applicable)

6.1. INSPECTION DURING OPERATION

The box cooler and the attached piping can be hot to touch. Check the surface temperature carefully before touching the box cooler or the piping.

During operation, regularly ⁶ inspect the following items:

- Check that the **pressure** does not exceed the design pressure (see section 2.4).
- Check that the **liquid temperatures** meet the expected values and are within the permissible design limits. If the outlet temperature of the liquid is increasing throughout longer periods of time, this may be an indication that the box cooler has become fouled (internally or externally). In that case further inspection and cleaning may be necessary. See section 6.2 and 6.3.
- Check the **flow speed**. A too high flow speed (> 2.0 m/s) may cause erosion corrosion.
- Check if there is still **air trapped** in the system. Carefully and slowly open the vent and bleed the system until no more air escapes. Proper system bleeding is required to ensure optimal heat transfer and to prevent water hammer.
- Check for any **leaks** or signs of leakage. Apart from direct observation, other signs for leakage are loss of pressure, loss of cooling water and/or air keeps coming into the system.

Note that the leakage can also be to the outside of the ship, as the pressure in the system is higher than the seawater pressure.

Examine the cause (see section 7) and repair leaks when possible or contact Duramax Marine®.
- Check the tightness of all **bolted connections**. Verify also that no bolts or nuts are missing or broken. Replace or retighten when needed (see section 4.4.4).
- Inspect all surfaces for signs of **corrosion** and check the condition of **coatings**. Pay special attention to the top plate and the mounting frame, as these may be attacked by galvanic corrosion.

⁶ The intervals between the following inspection and maintenance activities are dependant upon the operating conditions.

After maintenance or repairs it may be necessary to increase the frequency of the inspections temporarily.

6.2. INTERNAL INSPECTION AND TUBE PLUGGING



Hot fluid under pressure

Do not remove the piping or water covers until:

- the system has been shut down (see section 5.3).
- the box cooler has been isolated from the system piping system, e.g. by closing the service valves in the supply and return piping.
- the box cooler and the attached piping are cooled down to a safe temperature.
- all pressure in the box cooler has been relieved (slowly open the vent valve).
- all liquid inside the system has been drained



Severe water leakage

The tube sheet to top plate connection is below the waterline. Loosening the collar bolts/Allen head screws of the tube bundle will result into severe water leakage and is a breakdown of the watertight integrity of the vessel.

DO NOT REMOVE THE TUBE BUNDLE OR THE COLLAR BOLTS/ALLEN HEAD SCREWS WHEN THE VESSEL IS AFLOAT!

Internal inspection and tube plugging can take place when the ship is afloat, as long as the collar bolts/Allen head screws remain secured.

- 1) Remove the supply and return pipes
- 2) Disassemble the water cover by loosening the bolts and nuts of the water cover.



Do not loosen the collar bolts / Allen head screws!

- 3) Carefully lift the water cover (see section 3.2).

Mind the weight. Take care not to damage the coating nor the gasket faces of the flanges.

- 4) Inspect the interior for fouling or signs of corrosion.

(It is not expected that internal cleaning of the tubes will be necessary because the liquid should be conditioned and circulates in a closed circuit.)

Flush each tube separately with a jet of water to check if the tubes are clogged in the bends.

Clogged tubes or excessive fouling will reduce the heat transfer and may contribute to internal corrosion of the tubes, as deposits may retain corrosive elements.

When cleaning is required, refer to section 6.3.

Note that internal cleaning requires that the tube bundle is dismantled from the top plate of the sea chest. Therefore this can only be done during dry-docking periods.

- 5) Removal of the water cover also allows for the identification of possible leaks in the tubes, as a leak will cause seawater to seep into the tubes.

An emergency repair can be done by plugging both ends of the damaged (leaking) tube.

Brass plugs can be obtained from Duramax Marine® or they can be made from free-machining brass (CuZn39Pb3). Alternatively, plugs can also be made from wood. The use of other material may damage the tube sheet.

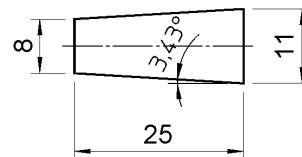

Figure 15. Dimensions of tube plugs for the CuZn20Al2 tubes \varnothing 11 x 0,8 mm.

- 6) After inspection or repairs, install the water cover and the piping according to the instructions of section 4.3.4 and 4.4.

Use new gaskets, do not reuse old gaskets.

- 7) Re-commission and start the box cooler according the instructions of sections 5.1 and 5.2

6.3. MAINTENANCE DURING EACH DRY-DOCKING PERIOD

To continually deliver full heat transfer capacity, both internal and external heat transfer surfaces must be maintained clean and free of corrosion.

Inspect, clean and service the tube bundle and the sea chest every dry-docking period.

6.3.1. Dismounting the tube bundle

For external inspection and cleaning, the tube bundle needs to be dismantled:

- 1) Remove the water cover according to the instructions of section 6.2.
- 2) To dismount the tube bundle, loosen the collar bolts.

Do not remove the tube bundle or the collar bolts/Allen head screws when the vessel is afloat!

- 3) Tighten the M16 eyebolts into the tube sheet (see section 3.2).
- 4) Carefully and slowly lift or lower the tube bundle out of the sea chest.

Mind the weight. Take care not to damage the coating or the surfaces of flanges.

- 5) Move the tube bundle to a place where inspection and cleaning can take place. Prevent damaging the tubes and the coating. Put it down on a soft surface, e.g. a sheet of rubber.

6.3.2. Cleaning of the tube bundle

- **Internal tube cleaning.** When the tubes are excessively fouled on the inside or when bends are clogged (see also section 6.2), the tube bundle can be cleaned by putting it in a container with water and cleaning chemicals.

Alternatively, it can be cleaned ultrasonically.

When using this type of cleaning, contact a competent company that specialises in ultrasonic or chemical cleaning and/or cleaning agents. Supply the company with full characteristics of used water, the materials of the box cooler and its use.

When required, contact Duramax Marine® for advice.

- **External cleaning of the tube bundle.** Excessive marine fouling will significantly reduce the heat transfer.

When cleaning is required, proceed as follows:

- 1) Scrape off the marine growth at the outside of the tube bundle with a wooden or plastic scraper or use a non-metallic brush.

Use wooden or plastic scraper with a maximum thickness of 5 mm to clean between the tubes.

Prevent damaging the coating or the surface of uncoated tubes. Do NOT use metal scrapers or metal brushes.

- 2) For coated box coolers: after mechanical cleaning, clean the tube bundle with a steam cleaner set at a maximum temperature of 120°C.

Next clean the tube bundle for 15 minutes with a solution of chloride (5 mg Cl per litre).

- 3) Finally, rinse the tube bundle thoroughly with clean unheated water, using a high pressure cleaner at a maximum pressure of 100 bar.

When using other cleaning methods contact a competent company that specialises in chemical cleaning and/or cleaning agents. Supply the company with full characteristics of the materials of the box cooler and its use.

- 4) Check if the heat cured duroplast coating of the tube bundle is damaged (when applicable).

A damaged coating (also small damages) will lead to accelerated (galvanic) corrosion.

Small coating damages can be touched up by a special two-component repair set, which can be ordered from Duramax Marine®. When larger areas are damaged, the complete tube bundle needs to be re-coated. In that case contact Duramax Marine®.

6.3.3. Damaged tubes

When the tubes are damaged, contact Duramax Marine® for advice.

6.3.4. Inspection and maintenance of the sea chest

Clean the sea chest and check for signs of corrosion and coating damage, which may have been covered by marine growth (especially the top plate and the mounting frame).

Repair when necessary to prevent galvanic corrosion.

When a new coating is applied, **do not coat the tube bundle, the copper anodes and cathode plates of the ICAF system or the sacrificial anodes** (if applicable).

Inspect and clean the inlet and outlet slots to ensure an unobstructed water flow.

6.3.5. Clean or replace the anodes

Replace the sacrificial anodes and the ICAF-anodes or clean them down to bare metal when replacement is not yet needed (refer also to the manual(s) from the manufacturer of the systems and observe all relevant maintenance instructions).

6.3.6. Re-install the water cover

After inspection and servicing, re-install the tube bundle and the water cover according to the instructions of sections 4.3 and 4.4.

Replace the gaskets - do not reuse the old gaskets.

Replace damaged bolts.

6.3.7. Pressure testing the box cooler

After re-installation it may be necessary to pressure test the box cooler.

- 1) Blind the nozzles with rubber gaskets (e.g., cut from rubber sheets) and properly sized blind flanges. Provide a manual air vent valve at the highest point to bleed off the air that is present in the system.
- 2) Fill the box cooler through a feeder with a suitable, non-corrosive, unheated liquid while the air vent is open. Close the vent after all air has been evacuated.
- 3) Raise the pressure to the test pressure shown on the type plate by using a suitable pump. Use a properly calibrated pressure gauge to adjust to the right pressure.

Pressurize the system for 30 minutes (at room temperature).

Do not overload, do not exceed the duration!

- 4) Inspect for leakage and loss of pressure during the time the box cooler is under pressure.

No leakage or residual deformation is permissible. In case of leakage, this needs to be repaired (see section 7).

- 5) Slowly de-pressurize the box cooler to atmospheric pressure.
- 6) Open the vent and drain the liquid completely. Rinse afterwards, when required.

6.3.8. Fit the piping and re-commission the box cooler

1. Re-install the piping according to the instructions of sections 4.7.
2. Replace all gaskets with new ones - do not reuse a used gasket.
3. Re-commission and start the box cooler according to the instructions of sections 5.1 and 5.2.

6.4. ORDERING SPARE PARTS

Order spare parts from Duramax Marine®. The following information should accompany spare parts orders:

- project number and order number
- complete description of type (see the technical specification or the type plate)
- required part (for a description, see the supplied documentation or the type plate)

7. MALFUNCTIONS



Troubleshooting may only be performed by suitably trained and qualified personnel

- Observe all applicable safety instructions of this manual!
- Immediately repair or correct each malfunction, defect or fault that may generate a hazard.

Refer to section 6 for instructions concerning inspection and repairs.

Malfunction	Possible cause
Excessive vibrations and abnormal noise	<ul style="list-style-type: none"> — air trapped in the box cooler. Open the vent and bleed until all air is out of the system — pressure fluctuations in circulating medium, defective or incorrect pump — vibrations or resonance transmitted to the box cooler from attached piping (see section 4.1.2)
Box cooler is leaking	<ul style="list-style-type: none"> — leakage at the nozzle to water cover joints. Too high nozzle loads, thermal expansion or vibrating piping. Contact Duramax Marine®. — defective tube. Seal the defective tube at both ends with tube plugs (see section 6.2). — defective tube – tube sheet connection. Contact Duramax Marine®. — leakage between pipe flanges. Re-tighten the bolts. Check the gasket faces for damage (see section 4.4.4). — leakage between tube sheet and mounting frame. Bolts insufficiently tightened. Re-tighten the bolts. — leakage between tube sheet and mounting frame. Mating flanges not flat or face surfaces damaged (see section 4.2). Re-tighten the bolts (see section 4.4.4). Contact Duramax Marine® if this does not succeed. — pressure and/or temperature too high (see section 5.2) — internal corrosion (contact Duramax Marine®) — wrong gaskets used (see sections 4.3 and 4.4) — abrasive or corrosive (cleaning) medium used — frost damage (see section 5.3) <p>After carrying out the corrective measures, pressure test the box cooler to make sure it is leak free, see section 6.3.7.</p>
Insufficient capacity <i>(can be determined by checking the temperatures of the medium and the air)</i>	<ul style="list-style-type: none"> — insufficient or incorrectly sized slot openings (see section 4.1) — air trapped in the sea chest — wave hollow occurring in the sea chest (see section 4.1) — sea chest (slots) too close to ship's propeller — box cooler too close to the walls of the sea chest (contact Duramax Marine®) — water cover mounted in the wrong way (see section 4.3.4) — medium inlet temperature or flow higher than specified — air trapped in the box cooler. Open the vent and bleed until all air is out of the system. — box cooler tubes are fouled, damaged or blocked (see section 6.2 and 6.3) — excessive marine growth on the tube bundle (see section 6.3.2)
Corrosion	<ul style="list-style-type: none"> — coatings damaged (on tube bundle and/or on sea chest) — sacrificial anode depleted or not installed. Contact Duramax Marine® for advice. — stray currents. Install sacrificial anodes and/or contact Duramax Marine®.

8. TECHNICAL SPECIFICATIONS

Please refer to the technical specifications as supplied with the order documents.

INNOVATION.
EXPERIENCE.
RESULTS.

Duramax Marine® is committed to providing excellence in every product we manufacture. Our Johnson Cutless® marine and industrial bearings, heat exchangers, impact protection systems and sealing systems are known worldwide for their engineered quality and dependable performance. Please contact the factory for information on any of the following Duramax Marine® products:



JOHNSON CUTLESS® WATER-LUBRICATED BEARING SYSTEMS

Johnson Cutless® Sleeve and Flanged Bearings

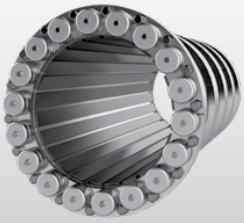

DURAMAX® ADVANCED WATER-LUBRICATED BEARING SYSTEMS

Johnson® Demountable Stave Bearings
ROMOR® I Stave Bearings and Segmental Housings
ROMOR® C- Partial Arc Bearings
DMX® Polymer Alloy Bearings
DuraBlue® Bearings, Rudder & Pintle Bushings, Thrust Washers, and Wear Pads
Industrial Pump Bearing Systems

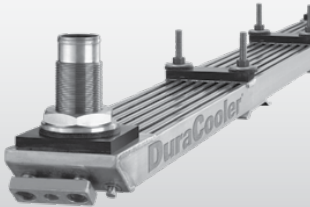

DURAMAX® HEAT EXCHANGE SYSTEMS

DuraCooler® Keel Coolers
Duramax® Demountable Keel Coolers
Duramax® BoxCoolers

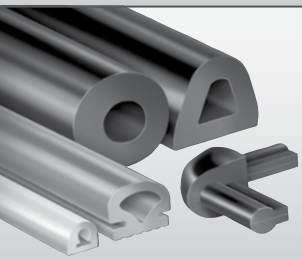

DURAMAX® IMPACT PROTECTION SYSTEMS

Johnson® Commercial Dock Bumpers, Fenders & Tow Knees
LINERITE® Composite Batterboard Systems



DURAMAX® SHAFT SEALING SYSTEMS

DryMax® Shaft Seal & Rudder Seal
Duramax® Mechanical Shaft Seal
Johnson® Heavy-Duty Air Seal Stuffing Boxes
Duramax® Ultra-X® High Performance Compression Packing

©2023 Duramax Marine®
17990 Great Lakes Parkway
Hiram, Ohio 44234 U.S.A.
PHONE 440.834.5400
FAX 440.834.4950
info@DuramaxMarine.com
www.DuramaxMarine.com

Duramax Marine® is an ISO 9001:2015 Certified Company

DURAMAX MARINE®